

***DigiTRAK***<sup>®</sup>

***Mark III Directional Drilling  
Locating System***

**Operator's Manual**

403-3000-00-F3, Aug 2013 (other document numbers and dates in this document are not applicable)

© 1999-2013 by Digital Control Incorporated. All rights reserved.

## **Trademarks**

The DCI logo, CableLink<sup>®</sup>, DataLog<sup>®</sup>, DigiTrak<sup>®</sup>, Eclipse<sup>®</sup>, iGPS<sup>®</sup>, Intuitive<sup>®</sup>, *look-ahead*<sup>®</sup>, SST<sup>®</sup>, *target-in-the-box*<sup>®</sup>, and *Target Steering*<sup>®</sup> are U.S. registered trademarks and DucTrak<sup>™</sup>, FasTrak<sup>™</sup>, SuperCell<sup>™</sup>, LT<sup>™</sup>, TeleLock<sup>™</sup>, and TensiTrak<sup>™</sup> are trademarks of Digital Control Incorporated.

## **Patents**

The DigiTrak<sup>®</sup> Locating System is covered by one or more of the following U.S. Patents: 5,155,442; 5,337,002; 5,444,382; 5,633,589; 5,698,981; 5,726,359; 5,764,062; 5,767,678; 5,878,824; 5,926,025; 5,933,008; 5,990,682; 6,002,258; 6,008,651; 6,014,026; 6,035,951; 6,057,687; 6,066,955; 6,160,401; 6,232,780; 6,396,275; 6,400,159; 6,525,538; 6,559,646; 6,593,745; 6,677,768; 6,693,429; 6,756,783; 6,756,784; 6,838,882; 6,924,645; 6,954,073; 7,015,697; 7,049,820; 7,061,244. Sale of a DigiTrak<sup>®</sup> Receiver does not convey a license under any patents covering the DigiTrak<sup>®</sup> Transmitter or underground drill housing. Other patents pending.

## **Important Notice**

All statements, technical information, and recommendations related to the products of Digital Control Incorporated (DCI) are based on information believed to be reliable, but the accuracy or completeness thereof is not warranted. Before utilizing any DCI product, the user should determine the suitability of the product for its intended use. All statements herein refer to DCI products as delivered by DCI and do not apply to any user customizations not authorized by DCI nor to any third-party products. Nothing herein shall constitute any warranty by DCI nor will anything herein be deemed to modify the terms of DCI's existing limited warranty applicable to all DCI products.

## **FCC Compliance Statement**

This equipment has been tested and found to comply with the limits for a Class B digital device, pursuant to Part 15 of the Rules of the Federal Communications Commission. These limits are designed to provide reasonable protection against harmful interference in a residential installation. This equipment generates, uses, and can radiate radio frequency energy and, if not installed and used in accordance with the instructions, may cause harmful interference to radio communications. However, there is no guarantee that interference will not occur in a particular installation. If this equipment does cause harmful interference to radio or television reception, which can be determined by turning the equipment off and on, the user is encouraged to try to correct the interference by one or more of the following measures:

- Reorient or relocate the DigiTrak Receiver.
- Increase the separation between the problematic equipment and the DigiTrak Receiver.
- Connect the equipment into an outlet on a different circuit.
- Consult the dealer for help.

Changes or modifications to the DCI equipment not expressly approved and carried out by DCI will void the user's limited warranty and the FCC's authorization to operate the equipment.

## Contact Us

<b>United States</b> <i>DCI Headquarters</i>	19625 62nd Ave S, Suite B103 Kent, Washington 98032, USA +1.425.251.0559 / 1.800.288.3610 +1.425.251.0702 fax <a href="mailto:dcidigital-control.com">dcidigital-control.com</a>
<b>Australia</b>	2/9 Frinton Street Southport QLD 4215 +61.7.5531.4283 +61.7.5531.2617 fax <a href="mailto:dciaustralia@digital-control.com">dciaustralia@digital-control.com</a>
<b>China</b>	368 Xingle Road Huacao Town Minhang District Shanghai 201107, P.R.C. +86.21.6432.5186 +86.21.6432.5187 fax <a href="mailto:dcichina@digital-control.com">dcichina@digital-control.com</a>
<b>Europe</b>	Brueckenstraße 2 97828 Marktheidenfeld Germany +49.9391.810.6100 +49.9391.810.6109 fax <a href="mailto:dcieurope@digital-control.com">dcieurope@digital-control.com</a>
<b>India</b>	DTJ 1023, 10th Floor DLF Tower A, DA District Center Jasola, New Delhi 110044 +91.11.4507.0444 +91.11.4507.0440 fax <a href="mailto:dcindia@digital-control.com">dcindia@digital-control.com</a>
<b>Russia</b>	Molodogvardeyskaya Street, 4 Building 1, Office 5 Moscow, Russia 121467 +7.499.281.8177 +7.499.281.8166 fax <a href="mailto:dcirusssia@digital-control.com">dcirusssia@digital-control.com</a>

# Table of Contents

SAFETY PRECAUTIONS AND WARNINGS .....	vi
INTRODUCTION .....	1
Basic DigiTrak Equipment .....	1
Basic DigiTrak Operation.....	2
Technical Support.....	3
RECEIVER .....	5
Display Window Icons .....	6
On/Off .....	7
Receiving the Transmitter's Signals .....	8
Clicking vs. Holding the Trigger .....	8
Changing the Receiver's Channel Setting.....	9
Changing the Depth Measurement Units (English vs. Metric) .....	10
Battery Status Display for Receiver and Transmitter .....	10
Warning Tones for Transmitter Overheat.....	11
Ultrasonic Function.....	11
Setting the Ultrasonic Distance or Height-Above-Ground Measurement.....	12
Zeroing the Ultrasonics.....	12
Calibrating the Receiver .....	13
1-Point Calibration Procedure .....	13
2-Point Calibration Procedure.....	14
Calibrating with Transmitter Underground at Shallow Depth (<10 ft) .....	16
Using Depth Antenna Plumb Line to Mark Locate Points .....	16
Finding Firmware Version.....	17
5.0 Series Firmware Functions.....	17
Predicted Depth Key Points .....	17
Procedure for Observing the Predicted Depth.....	18
Viewing the Transmitter's Temperature and the Receiver's Battery Status .....	18
Viewing the Receiver's Battery Voltage .....	18
Off Feature .....	18
Accessing the Receiver's Running Time Meter .....	18
TRANSMITTER .....	19
How a Transmitter Works .....	19
Batteries.....	20
Temperature Display .....	20
Battery Status Display .....	20
Temperature Overheat .....	20
Sleep Mode (Automatic Shutoff).....	21
Verifying Proper Fit of Transmitter in Housing .....	21
Locating the Transmitter.....	23
Sensitive-Pitch Transmitters.....	23
Transmitter as an Inclinometer.....	23
Serial Numbers.....	24
Specifications.....	24

## **Table of Contents (Cont.)**

REMOTE DISPLAY SYSTEM .....	25
On/Off and Setting the Channel .....	26
Transmitter Temperature and Battery Status .....	26
Remote Steering.....	27
Finding Firmware Version.....	28
DataLog Capability .....	28
BATTERY CHARGER .....	29
Charging a Battery.....	30
Conditioning a Battery in the Charger .....	31
Conditioning a Battery Manually.....	31
Indicator Lights and Meanings.....	31
SYSTEM OPERATING INSTRUCTIONS .....	33
Start-up Procedure .....	33
Shutdown Procedure .....	33
Moisture and Temperature Avoidance .....	33
Optimal Operating Temperatures.....	34
General Maintenance .....	34
SIGNAL INTERFERENCE .....	35
Electrical Interference/Background Noise Check.....	35
Suggestions for Dealing with Interference.....	36
OPERATIONAL TESTS .....	37
Self-Test for Mark III Receivers.....	37
Receiver Balance Check .....	37
Receiver Gain Test.....	38
Transmitter Tests.....	38
Transmitter Salt Water Range Test.....	40
Transmitter Battery Tests .....	41
LOCATING .....	43
Locate Points (FNLP & RNLP) and Locate Line (PLL) .....	43
Handling the Receiver .....	44
Distance Between FNLP and RNLP Due to Depth, Pitch, and Topography.....	44
Using Plus/Minus Indicators for Locating .....	45
Locating the Transmitter from the Drill .....	45
Finding the Rear Negative Locate Point (RNLP) .....	45
Finding the Positive Locate Line (PLL) .....	46
Finding the Front Negative Locate Point (FNLP).....	47
Finding the Transmitter and Its Depth.....	48
Locating the Transmitter from the Front.....	49
Method for Confirming Position .....	49
Locating on the Fly .....	50
Off-Track Locating .....	50
Splitting the Front and Rear Negative Locate Points .....	51
Four Turn Technique .....	51

## **Table of Contents (Cont.)**

LOCATING (Cont.)	
Calculating Depth Based on Distance Between FNLP & RNLP .....	52
Running Off Pitch or Calculating Depth from Pitch .....	53
Transmitter's Signal Shape .....	54
Antennae Configuration .....	54
Signal Reception .....	54
Front and Rear Negative Locate Points .....	55
Positive Locate Line Above Transmitter .....	55
CABLE TRANSMITTER SYSTEM .....	57
Power Supply .....	59
Cable Transmitter .....	60
Remote Display with Cable Transmitter Capability .....	61
Viewing the Cable System Battery Status .....	62
Operation .....	62
TROUBLESHOOTING .....	63
GLOSSARY .....	69
APPENDIX .....	73
Depth Increase in Inches per 10-foot Rod .....	74
Percent of Grade to Degree Conversions (1% Pitch Transmitters) .....	75
Percent of Grade to Degree Conversions (0.1% Pitch Transmitters or Sensitive Pitch) .....	76
Degree to Percent of Grade Conversions (1% Pitch Transmitters) .....	77
Degree to Percent of Grade Conversions (0.1% Pitch Transmitters) .....	78
Calculating Depth Based on Distance Between FNLP and RNLP .....	79
REMOTE TELEMETRY LICENSE	
LIMITED WARRANTY	

# ***Safety Precautions and Warnings***

**Important Note:** All operators must read and understand the following Safety Precautions and Warnings before using the DigiTrak Locating System.

☠ Serious injury and death can result if underground drilling equipment makes contact with an underground utility such as a high-voltage electrical cable or a natural gas line.

☞ Substantial property damage and liability can result if underground drilling equipment makes contact with an underground utility such as a telephone, fiber-optic, water, or sewer line.

☞ Work slowdown and cost overruns can occur if drilling operators do not use the drilling or locating equipment correctly to obtain proper performance.

- Directional drilling operators **MUST** at all times:
  - Understand the safe and proper operation of drilling and locating equipment, including the use of ground mats and proper grounding procedures.
  - Ensure that all underground utilities have been located, exposed, and marked accurately prior to drilling.
  - Wear protective safety clothing such as dielectric boots, gloves, hard-hats, high-visibility vests and safety glasses.
  - Locate and track the drill head accurately and correctly during drilling.
  - Comply with state and local governmental regulations (e.g., OSHA).
  - Follow all other safety procedures.
- The DigiTrak System cannot be used to locate utilities.
- Continued exposure to heat, due to frictional heating of the drill head from drilling in sand, gravel, or rock without sufficient fluid flow around the Transmitter, can cause inaccurate depth to be displayed and may permanently damage the Transmitter. For more information see “Temperature Overheat” in the Transmitter Section.

☞ The DigiTrak equipment is not explosion-proof and should never be used near flammable or explosive substances.

## ***Safety Precautions and Warnings (Continued)***

- Prior to the start of each drilling run, test the DigiTrak System to confirm that it is operating properly and check that it is providing accurate drill head location and heading information (see Receiver Section) and accurate drill head depth, pitch, and roll information with the Transmitter inside the drill head.
  
- During drilling, the depth will not be accurate unless:
  - The Receiver has been properly calibrated and the calibration has been checked for accuracy so that the Receiver shows the correct depth.
  - The drill head has been located correctly and accurately and the Receiver is directly above and parallel to the Transmitter in the tool underground or above the front negative locate point (FNLP).
  - The Receiver height-above-ground or ultrasonic distance has been set correctly.
  - The Receiver is kept level.
  
- Interference can cause inaccuracies in the measurement of depth and loss of pitch, roll, or the Transmitter's location or heading. The locating operator should perform an electrical interference check prior to drilling (see "Electrical Interference/Background Noise Check" in the Signal Interference Section).
  - Sources of interference include traffic signal loops, invisible dog fences, cable TV, power lines, fiber-trace lines, metal structures, cathodic protection, transmission towers, and radio frequencies.
  - Interference with the operation of the Remote Display may also occur from other sources operating nearby on the same frequency, such as car rental agencies using their remote check-in modules, other directional drilling locating equipment, etc.
  
- Carefully review this Operator's Manual and the DigiTrak training video and be sure you always operate the DigiTrak System properly to obtain accurate depth, pitch, roll, and locate points. If you have any questions about the operation of the DigiTrak System, please call DCI's Customer Service Department at 425-251-0559 or 800-288-3610 between the hours of 6:00 a.m. and 6:00 p.m. Pacific Time, Monday through Friday, and we will assist you in any way possible.

**REMEMBER**

**If you are having difficulty on the job, call DCI (425-251-0559 or 800-288-3610) and we'll attempt to help you solve the problem.**



## ***Dear Customer:***

We would like to thank you for choosing the DigiTrak Locating System. We are proud of the equipment that we have been designing and building in Washington State since 1990. We believe strongly in providing a unique, high-quality product *and* standing behind it with superior customer service and training.

We ask that you take the time to read this entire manual—especially the section on safety. Also, please fill in the warranty registration and mail it in or fax it to us at 253-395-2800. We will put you on the Digital Control mailing list and send you product upgrade information and our monthly newsletter *FasTrak*™.

We also ask that you feel free to contact us at 425-251-0559 or 800-288-3610 if you are experiencing any problems with the equipment or have any questions regarding its use. Our Customer Service Department is available to provide assistance.

The DigiTrak equipment has evolved considerably since the first Mark I system in 1990. Many of the improvements to the equipment have been made in response to our customer's needs and suggestions. This manual is written for all versions of the equipment—from our first units to the most recent Mark III.

As this industry grows, we try to keep an eye on the future to develop equipment that will make your job faster and easier. We encourage you to stay current by visiting our web site on the Internet at [www.digitrak.com](http://www.digitrak.com) or calling us at 425-251-0559 or 800-288-3610.

We welcome questions, comments, and ideas.

Digital Control Incorporated  
Kent, Washington  
May 2008

## Introduction

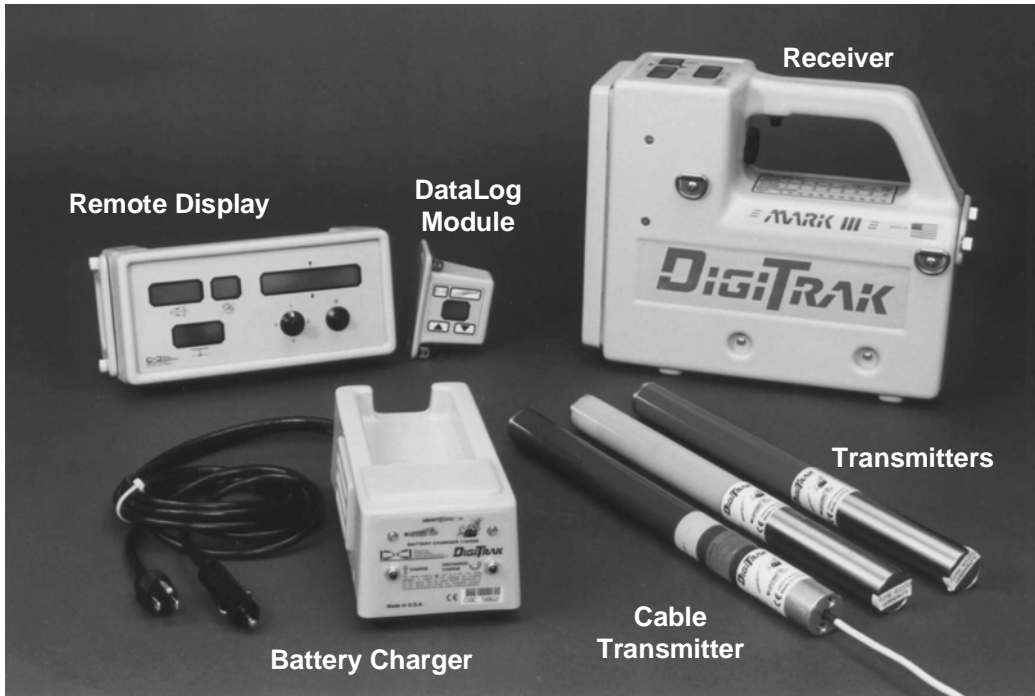

***DigiTrak<sup>®</sup> Directional Drilling Locating System***

The DigiTrak Locating System is used during horizontal directional drilling operations for locating and tracking the transmitter within the tool. This manual provides detailed information about the DigiTrak System and how to use it. The main system components are the Receiver, the Transmitter, the Remote Display, and the Battery Charger, which are described below. The optional DataLog<sup>®</sup> System can be used with the DigiTrak equipment to record and map your drilling data. These systems can be upgraded for use with the Cable Transmitter System, providing locating capability up to 140 ft (42.7 m) from the transmitter.

### Basic DigiTrak Equipment

**Receiver** – The DigiTrak Receiver receives signals from the transmitter, processes the signal information, and displays the transmitter's status (roll, pitch, depth/distance, predicted depth, battery, and temperature). It may also be equipped to send this information to the remote display at the drill. The most current model of DigiTrak Receivers is the Mark III. Older versions are the Mark II or Mark I. Only on the Mark III Receiver is the version identified; older versions are not specified on the receiver. If you need to know what version you have, you can contact DCI.

**Transmitter** – Also referred to as a sonde, beacon, or probe, the DigiTrak Transmitter is placed in the drill tool/housing to send information to the receiver. The receiver displays depth/distance, signal strength, pitch, roll, battery, and temperature status. Power is supplied using C-cell alkaline batteries, except for

the optional cable transmitter, which requires a 12V to 28V DC system. For gravity sewer installations, DCI manufactures a sensitive-pitch transmitter that measures pitch in 0.1% increments.

**Remote Display** – The DigiTrak Remote Display unit enables the drill operator to view the transmitter's pitch, roll, depth, predicted depth, and temperature, and can also be used for remote steering when walk-over tracking is not possible.

**Battery Charger** – The DigiTrak Battery Charger is used to charge and condition the DigiTrak NiCad battery packs. May be used with AC or DC sources and is easily adapted for worldwide usage.

**DataLog System** – The DigiTrak DataLog System is an optional “as-built” mapping system used for recording and plotting the borepath location.

**Cable Transmitter System** – The DigiTrak Cable Transmitter System is an optional add-on deep locating system used for borepaths that are deeper than 50 ft (15 m), have lengths that require several days to drill, do not allow walkover locating, and/or are in high-interference areas.

## Basic DigiTrak Operation

**Safety Precautions and Warnings** – All DigiTrak operators must review the safety precautions and warnings provided at the front of this manual before using the DigiTrak System.

**Trigger Click / Hold** – The trigger under the receiver's handle can be either clicked (pushed in and immediately released in less than ½ second) or held in. These two actions provide different results and are used in different operating procedures. (see “Clicking vs. Holding the Trigger” in the Receiver Section)

**Calibration** – The DigiTrak System requires calibration prior to first time use and when any of the following equipment is introduced: transmitter, receiver, or transmitter housing. Calibration is not required every day; however, DCI recommends you verify the calibration by checking the distance readings (bottom window) with a tape measure prior to the beginning of each drilling run. (see “Calibrating the Receiver” in the Receiver Section)

**Ultrasonic Distance / Height-Above-Ground Measurement** – The ultrasonic distance or height-above-ground measurement is the distance between the DigiTrak Receiver and the ground. This distance is measured by the two ultrasonic transducers on the bottom of the receiver. (see “Ultrasonic Function” in the Receiver Section)

**Depth vs. Distance** – When the trigger is not held in, the bottom window of the receiver displays the distance from the receiver to the transmitter, unless the receiver is out of range of the transmitter. Once the receiver is on and calibrated, it is not necessary to wait for depth readings because the receiver continuously measures this distance. When the receiver is directly above the transmitter, the information in the bottom window is referred to as the depth. When the receiver is not directly above the transmitter, the number in the bottom window is referred to as the “slant” distance. (see “Clicking vs. Holding the Trigger” in the Receiver Section)

**Predicted Depth** – If the trigger is held in, the bottom window will display the predicted depth, which will only be accurate if the receiver is at the front negative locate point (FNLP). The predicted depth is displayed in the bottom window as a flashing number with a solid squiggle. (see “Clicking vs. Holding the Trigger” and “5.0 Series Firmware Functions” in the Receiver Section)

**Operational Tests** – Before drilling and during operation it is necessary to check the following: proper calibration, correct ultrasonic measurement, status of battery power, transmitter temperature, and signal interference problems. (see Operational Tests Section)

**Locating** – The DigiTrak System is used to locate the transmitter underground; the trigger under the receiver's handle is held in during locating to show signal strength in the upper left window. The operator systematically follows the signals received from the transmitter to establish the FNLP and the rear negative locate point (RNLP), which then guide the operator to the transmitter's location. (see Locating Section)

**Tracking** – The DigiTrak Receiver automatically “tracks” and displays the transmitter's orientation (pitch/roll) and distance. It is not necessary to push the trigger or take any other steps to see this information.

**Troubleshooting** – The DigiTrak System is a sensitive instrument whose operation can be affected by many different factors. We have listed many of the common problems and solutions in the Troubleshooting Section in this manual. If you cannot find the answers you need there, then please call DCI for assistance. (see “Technical Support” below)

## Technical Support

If you are having difficulties with your DigiTrak System and cannot find solutions by reviewing this manual or the DigiTrak Training Video, then call DCI's Customer Service Department at 425-251-0559 or 800-288-3610. When you call, you should be prepared to provide the following information:

- Serial numbers on the DigiTrak Receiver, Transmitter, Remote Display, etc.
- Description of problem.
- How you have tried to solve the problem.
- Availability of other equipment to troubleshoot with.

You may also want to visit our web site ([www.digitrak.com](http://www.digitrak.com)) for more information, or e-mail us at [DCI@digital-control.com](mailto:DCI@digital-control.com).

## **Notes**

# Receiver

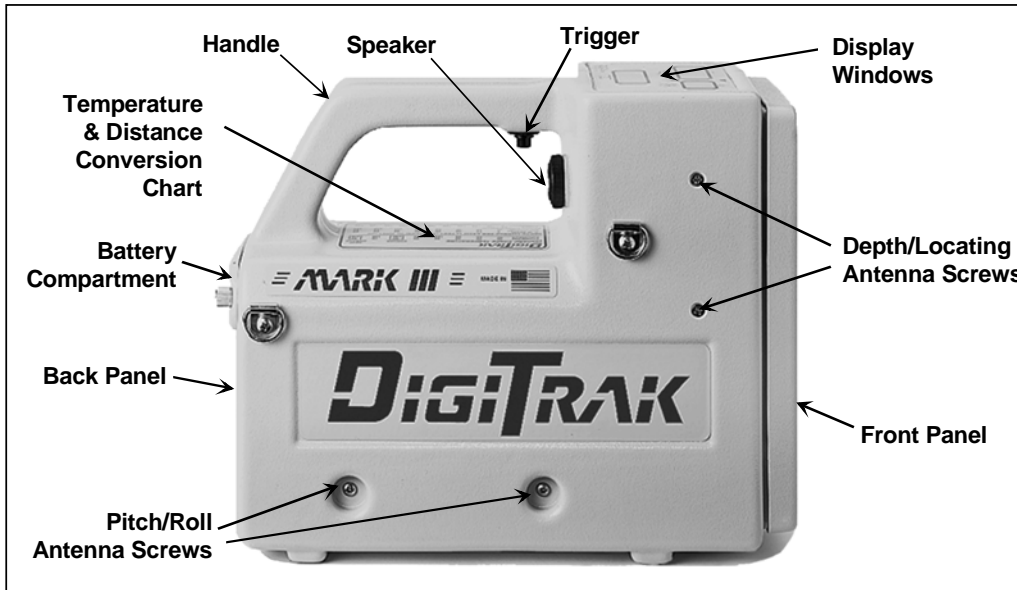

**DigiTrak Receiver – Side View**

The DigiTrak Receiver is a hand-held unit used for locating and tracking the transmitter. It receives and converts signals from the transmitter and displays the following information: pitch, roll, depth/distance, predicted depth, temperature, and battery status. The display windows are located on the top of the receiver.

Next to each DigiTrak display window are symbols or icons to help you identify the functions of each window (see table on next page). The icons below each window represent the pitch, roll, and depth/distance of the transmitter, which are displayed when the trigger is released, as shown by the trigger down icon. When the trigger is held in (trigger up), the top left window will display the signal strength and the top right window will display the temperature. Note the predicted depth icon below the bottom window. When the trigger is held in and the receiver is positioned at the front negative locate point (FNLP), the predicted depth of the transmitter at the FNLP is displayed in the bottom window. This predicted depth number will flash quickly and the bottom window will also show a solidly illuminated squiggle (“~”) to further set it apart from the depth display.

**NOTE:** Should the trigger be held in at any location other than the FNLP, the predicted depth shown will not be valid.

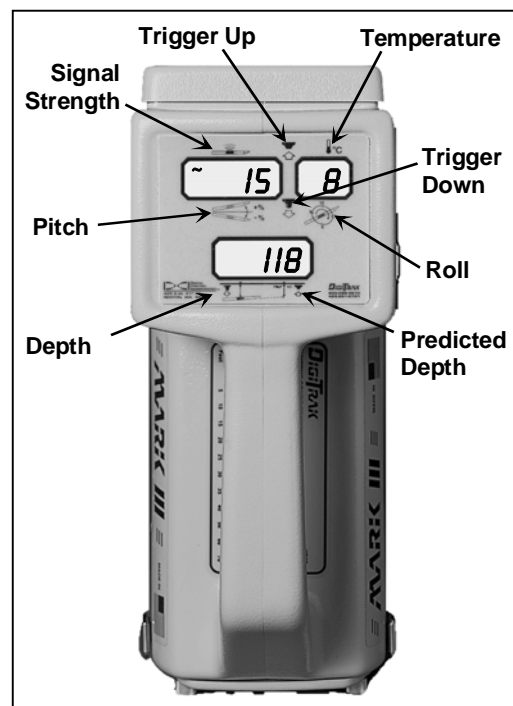

**DigiTrak Receiver – Top View Showing Display Window Icons**

## Display Window Icons

	<b>Trigger down</b> – Trigger is released; display windows show pitch, roll, and distance/depth of the transmitter.
	<b>Pitch</b> – Numbers from 0% to $\pm 100\%$ show the inclination of the transmitter with respect to horizontal; 100% represents a 45° angle (top left window, trigger down).
	<b>Roll</b> – Numbers from 1 to 12 show the roll position (1 o'clock to 12 o'clock) of the transmitter (top right window, trigger down).
	<b>Depth</b> – The bottom window displays the depth or slant distance of the transmitter with respect to the surface of the ground when the trigger is down.
	<b>Trigger up</b> – Trigger is held in; display windows show signal strength, transmitter temperature, and predicted depth when operator is at FNLP.
	<b>Signal strength</b> – Numbers from 0 to 999 are displayed to show the strength of the signal from the transmitter (top left window, trigger up).
	<b>Transmitter temperature</b> – Temperature of the transmitter in degrees Celsius (top right window, trigger up).
	<b>Predicted depth</b> – The bottom window displays the predicted depth of the transmitter at the FNLP when the trigger is up and the receiver is at the FNLP.

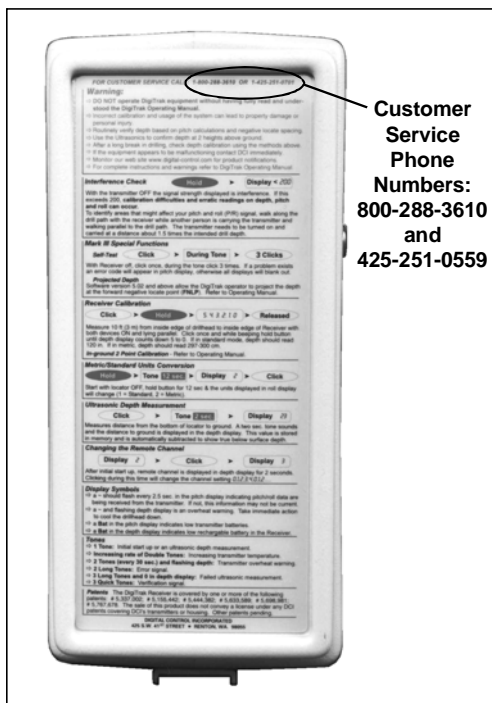

**DigiTrak Receiver – Front Panel Showing Condensed Instructions**

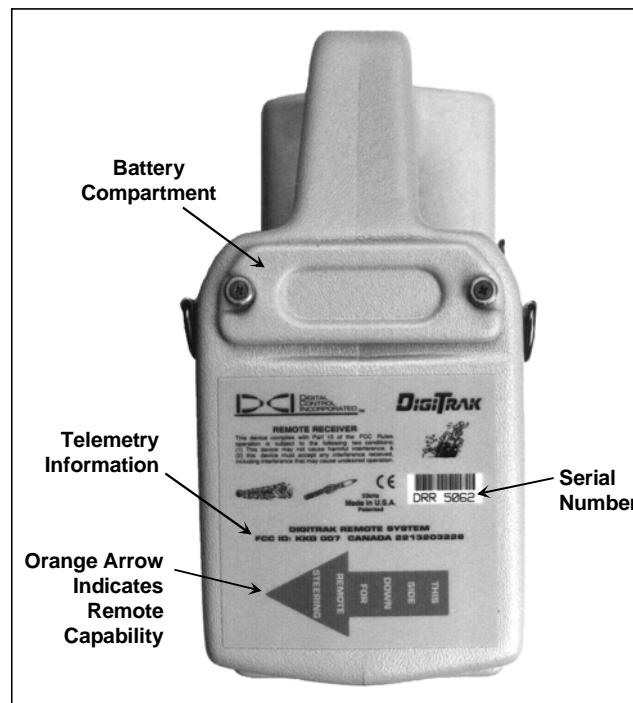

**DigiTrak Receiver – Back Side Showing Identification Information**

The front panel of the receiver has condensed instructions for quick field reference and DCI's phone numbers for troubleshooting assistance. There is also a sticker under the handle for temperature and distance conversions. The serial number is located on the back panel of the unit below the battery compartment; it is preceded by the letters DR or DRR (for DigiTrak Receiver and DigiTrak Remote Receiver,

respectively). If there is an orange arrow below the serial number, then it is a remote receiver, and it is capable of sending a signal to a remote display unit at the drill. All receivers can be upgraded to remote capability. The Mark III Receivers (serial numbers greater than 4676) are also equipped with a backlit display for dim viewing conditions. All receivers can be upgraded to have a backlit display.

DigiTrak equipment is like a computer in that it requires firmware. The firmware determines how a unit will convey information. Over time, the firmware is changed and upgraded to accommodate new features and functions in the system. New versions of the firmware are available for upgrading older systems, but the firmware must be upgraded by DCI. To determine the firmware version installed in your equipment, see “Finding Firmware Version” in the Receiver and Remote Display Sections.

All Mark III Receivers have the capability of performing a self-test to determine if the unit appears to be operating properly. DCI recommends that you complete the self-test every day before locating (see “Self-Test for Mark III Receivers” in the Operational Tests Section).

**IMPORTANT:** The receiver is designed to be held comfortably in such a manner that it levels itself. Keeping the receiver level is critical for the most accurate locating.

## On/Off

### To turn the receiver on:

1. Place a fully charged battery pack into the battery compartment, terminal end in first.
2. Click the trigger one time. The unit will sound a tone from the speaker adjacent to the trigger.
3. During the start-up sequence, the three display windows will quickly flash the following information, in the order given here:
  - **Top Left Window:** Firmware version in the receiver (version is shown with no decimal point—e.g., 507 is version 5.07); older units will display the firmware version only if the trigger is held in at start-up.
  - **Bottom Window:** Receiver’s battery voltage in tenths of a volt (155 is 15.5V DC); older units will not display this information.
  - **Top Right Window:** English or metric depth measurement units (1 = inches, 2 = centimeters).
  - **All Windows:** LCD test (888’s and all symbols will display).
  - **Bottom Window:** Remote channel setting (0 = off, 1,2,3,4 = on).

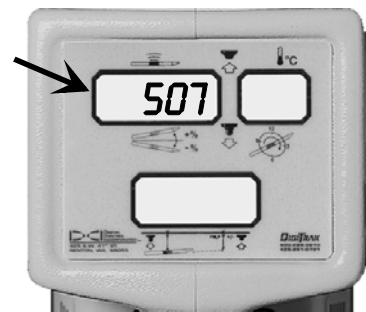

**Firmware Version**

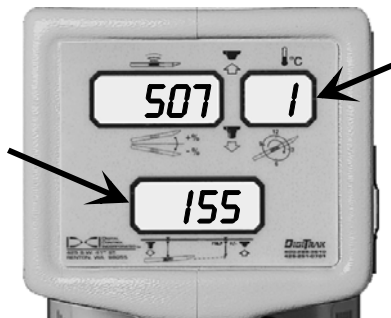

**Depth Measurement Units and Receiver Battery Voltage**

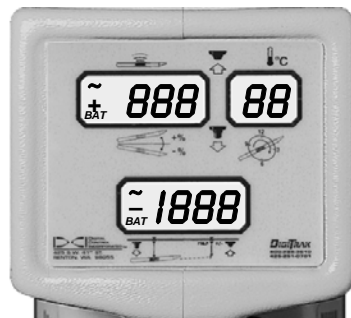

**LCD Test**

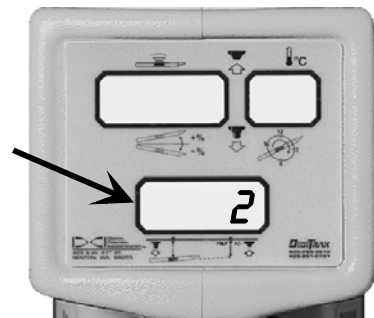

**Remote Channel Setting**



The depth measurement units (centimeters or inches) and remote channel setting can be changed only during start-up (see “Changing Depth Measurement Units” and “Changing the Channel Setting” below).

After the start-up process, the windows will display pitch, roll, and distance if there is an active transmitter within range (see Tracking Mode display below). If an active transmitter is not within range, 1999 will appear in the bottom window and the top windows will be blank. If the bottom window is not displaying 1999 and there is no active transmitter within range, an unknown signal is present.

### To turn the receiver off:

The receiver will automatically shut itself off if no signal is received for 15 minutes.

To turn off a receiver when a signal is present, click the trigger once and, during the tone, quickly click 4 times. All windows will blank out, signifying that the unit is off.

To turn off a receiver with pre-5.0 series firmware when a signal is present, the battery must be removed manually.

(For more information on the 5.0 series firmware and operating/display differences, see “Clicking vs. Holding the Trigger” and “5.0 Series Firmware Functions” in this section.)

## Receiving the Transmitter’s Signals

After charged batteries are loaded into the transmitter (positive end first), the receiver enters “tracking” mode and will display pitch in the top left window, roll (12 positions) in the top right window, and depth (or distance) in the bottom window. With the DigiTrak System it is not necessary to push any buttons to receive pitch, roll, or depth/distance; this information is updated and displayed automatically. The flashing squiggle (“~”) in the top left window indicates that pitch and roll updates are being received from the transmitter. For the best results, wait for two squiggles with the same pitch/roll information before giving a steering command to confirm the accuracy of the data.



***Tracking Mode Showing Pitch, Roll, Depth/Distance, and Update Symbol***

## Clicking vs. Holding the Trigger

**Clicking** the trigger versus **holding** the trigger will initiate different modes with your receiver. When the trigger is **held in** (trigger up) the receiver is in the “locating” mode, and the top left window will display signal strength. Also displayed in the top left window, along with the signal strength, are the plus (“+”) and minus (“-”) symbols. These symbols are the key to locating the transmitter (see Locating Section). The bottom window will display the predicted depth, along with a flashing squiggle. The top right window will flash the transmitter’s temperature in degrees Celsius.



***Locating Mode Showing Signal Strength, Transmitter Temperature, and Predicted Depth***



For receivers that have pre-5.0 series firmware, the bottom window will continue to display the receiver's distance from the transmitter in the bottom window, **not** the predicted depth. (For more information, see "5.0 Series Firmware Functions" in this section or see the Locating Section.)

Any time the trigger is **clicked** (pushed in and released in less than ½ second), the receiver will initiate an ultrasonic measurement, which is also referred to as the height-above-ground measurement. This measurement is the distance between the receiver and the ground, which is measured by the ultrasonic transducers on the bottom of the receiver. An ultrasonic measurement can be taken an unlimited number of times (reset) without affecting the receiver's calibration. The ultrasonic function is independent of the transmitter and measures the receiver's elevation above the ground. The ultrasonic distance is automatically subtracted from the distance to the transmitter to provide the operator with a display of the transmitter's depth/distance below the ground's surface. The ultrasonics were designed to reduce the effects of interference by increasing the separation between the interference source in the ground (e.g., rebar) and the receiver. (For more information, see "Ultrasonic Function" later in this section.)

## Changing the Receiver's Channel Setting

If using a remote display unit, the receiver and remote display unit must each be set to the same channel. Changing the receiver's channel selection can only be done at start-up.

### To change the channel:

At the end of the start-up sequence, the bottom window will display the current remote channel setting (0, 1, 2, 3, or 4) for 2 seconds. During this time, the trigger can be clicked to change the channel to the desired setting. This setting will remain until you change it. Replacing the batteries in any piece of equipment will not affect the current channel setting, the ultrasonic setting, or the receiver's calibration.

**NOTE:** A zero (0) remote channel setting indicates that the receiver's telemetry signal is shut off and no signal is being sent to the remote display unit. "Dashes" will appear across the three display windows on the remote display to indicate no signal is being received. Setting the receiver to channel 0 can be done to conserve the receiver's battery (see Remote Display Section).

The DigiTrak System uses ultrahigh-frequency telemetry to communicate between the receiver and the remote display. Both the receiver and the remote display must have the same type of telemetry to communicate properly.

## Changing the Depth Measurement Units (English vs. Metric)

The DigiTrak Receiver is capable of displaying depth in either inches (English) or centimeters (metric). The depth measurement units can *only* be changed during the start-up process.

### To change the measurement units:

Instead of clicking the trigger to initiate start-up, simply squeeze and hold in the trigger for 12-14 seconds (the unit may or may not make a tone during this time depending upon the firmware version). The top right window will display a 1 or a 2 (1 = inches, 2 = centimeters). With the trigger still held in, the unit will beep 3 times and then change to the other setting. When the desired setting is displayed, release the trigger. This mode will remain the same until changed and is not affected by battery replacement.

Older receivers that have not been upgraded require a different method for changing the depth measurement units. Contact DCI Customer Service (425-251-0559 or 800-288-3610) for assistance.

## Battery Status Display for Receiver and Transmitter

The receiver will prompt the operator when the rechargeable NiCad battery is low (approximately 1 hour of usage left) by displaying BAT in the bottom window.

The receiver's battery voltage is displayed in the bottom window during start-up. It is the first information to be displayed in the bottom window. The voltage is shown in tenths of a volt, for example, 155 is 15.5V DC. (For more information about the NiCad's associated voltages, see the Battery Charger Section.)

The percentage of remaining battery life in the receiver will display in the top right window after releasing a held-in trigger (locating mode). It will display only as 99, 90, 75, 50, 25, 10, 5, or 0.

If you observe the BAT symbol in the top left window, then the transmitter batteries are low, and the transmitter battery status should be checked. To view the percentage of battery life remaining in the transmitter's battery, hold and then release the trigger. The status is displayed in the top left window for 2 seconds, after which the pitch display will resume. This information will display only as 100, 90, 75, 50, 25, 10, 5, or 0. The receiver's NiCad battery percent remaining also displays during this 2-second period in the top right window.

**NOTE:** Mark III Receivers do not display the transmitter battery and temperature information until 4 minutes after start-up.

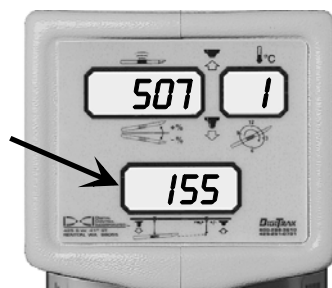

**Receiver Battery Status, Voltage Remaining**

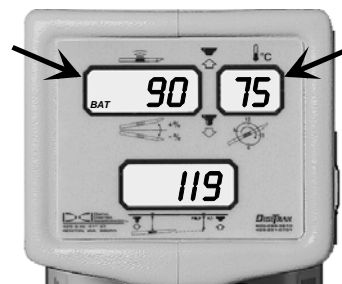

**Transmitter (left) and Receiver (right) Battery Life Remaining in Percentages**

## Warning Tones for Transmitter Overheat

Beginning with firmware version 3.76, the DigiTrak Receiver will emit a series of increasing warning tones to signal transmitter overheating as follows:

Temperature Range	Warning Signal
14°C and below	No audio or visual warnings.
15°C to 35°C	One double tone with every 4°C increase in temperature.
36°C to 45°C	Two double tones with every 4°C increase in temperature.
45°C to 60°C	Three double tones with every 4°C increase in temperature.
60°C and above	Audible error tones (two long tones) and the bottom window will flash; 1999 may appear when the transmitter shuts down at about 80°C.

## Ultrasonic Function

The ultrasonic function measures the receiver's elevation above the ground and subtracts that distance from the total magnetic distance to calculate the depth of the transmitter below the ground's surface. The ultrasonic function is designed to help the operator observe the depth reading while maintaining separation between the receiver's antennas and potential sources of interference. An ultrasonic measurement can only be taken after start-up is completed.

The ultrasonic function is particularly useful when:

- Locating over obstacles.
- Obtaining adequate separation from utilities in the ground or rebar interference.
- Locating above water.
- Verifying calibration when the transmitter is underground.
- Recalibrating in the ground (see "2-Point Calibration" below).

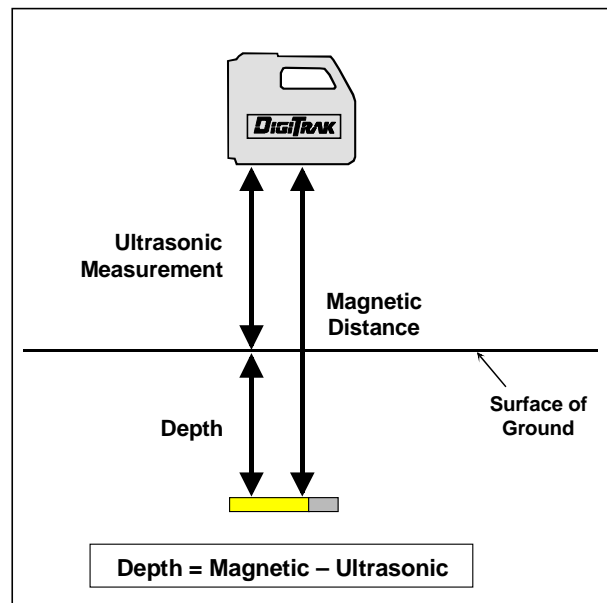

**Use of Ultrasonic Measurement To Determine Actual Depth**

The ultrasonic measurement is made by emitting and receiving signals from the two small round holes/ where transducers are mounted on the bottom of the receiver. When the trigger is clicked, one transducer emits a high-frequency sound wave that travels to the nearest surface and bounces back to be received by the other transducer. The time required for the signal to return is used to calculate the distance to the ground. The operating range of the ultrasonic measurement is between 12 inches (30 cm) and 90 inches (230 cm). The ultrasonic measurement is displayed in the bottom window for 2 seconds after the trigger is clicked one time.

Following are some general points regarding the ultrasonic function:

- The ultrasonic function in the receiver is independent of the transmitter receiving functions.
- A single click to activate the ultrasonic function can be used an unlimited number of times without affecting the receiver's calibration.
- The ultrasonic measurement is held in memory until the trigger is clicked again for a new ultrasonic measurement or until the receiver turns off.
- The ultrasonic measurement will be reset to zero after completing a 1-point calibration.
- The ultrasonic setting will require resetting after a 2-point calibration.

## ***Setting the Ultrasonic Distance or Height-Above-Ground Measurement***

1. Hold the receiver comfortably and level in your hand as you would during locating/tracking.
2. Click the trigger (the receiver must already be powered up). This will initiate the ultrasonic measurement.
3. A single tone is emitted during which the ultrasonic distance is displayed for 2 seconds in the bottom window before the depth/distance display resumes. The bottom window will now display the transmitter's depth below the ground instead of the total magnetic distance.

## ***Zeroing the Ultrasonics***

1. Set the receiver on the ground or against some other flat surface.
2. Click the trigger (the receiver must already be powered up). This will initiate the ultrasonic measurement.
3. The receiver will beep 3 times and display a "0" in the bottom window for 2 seconds before the depth display resumes.

**IMPORTANT:** If another crew member takes over the locating and does not reset the ultrasonics, the depth display may be inaccurate. For instance, if one person holds the DigiTrak Receiver comfortably 20 inches (50 cm) above the surface of the ground, and another person begins to locate the tool by setting the DigiTrak on the ground (without zeroing the ultrasonics), the tool will appear to be 20 inches shallower because the DigiTrak is still subtracting the 20-inch ultrasonic distance.

**NOTE:** If by chance the trigger is clicked twice within a 1 or 2 second period, the receiver will enter into a 2-point calibration mode. Wait until all the tones stop before touching the trigger again. Otherwise the calibration could be changed.

## Calibrating the Receiver

There are two different calibration methods: 1-point and 2-point. The 1-point calibration is performed with the transmitter in the housing parallel to and 10 ft 5 in. (3.18 m) from the receiver, as described below. A 2-point calibration is generally performed when the transmitter is below ground and it is not possible to perform a 1-point calibration.

**Calibration is necessary prior to first time use and when any of the following occur:**

- The transmitter is changed.
- The receiver is changed.
- The housing/drill tool is changed.

**Do not calibrate if:**

- You are within 10 ft (3 m) of metal structures, such as steel pipe, chain link fence, metal siding, construction equipment, or automobiles.
- The receiver is over rebar or underground utilities.
- The receiver is in the vicinity of excessive electrical interference (see “Electrical Interference/Background Noise Check” in the Signal Interference Section).
- The transmitter is not installed into the housing.
- The transmitter is not turned on.

**NOTE:** Calibration should be checked at 10 ft 5 in. (3.18 m) daily and before every use. Calibration only affects the depth/distance reading, not pitch or roll.

### 1-Point Calibration Procedure

1. Confirm the lack of interference (see “Electrical Interference/Background Noise” Check in the Signal Interference Section). Make sure there are no other active transmitters within range of the receiver.
2. Place an operating transmitter inside the housing on level ground.
3. After the receiver has completed the start-up sequence, place it exactly 10 ft 5 in. (3.18 m) from the housing as shown in the sketch (a tape measure must be used for accuracy; measure from centerline of transmitter to inside edge of receiver). Hold in the trigger to confirm a stable signal, then release the trigger; note signal strength reading. The signal strength must be at least 250 points for proper calibration. If your reading is less than 250, the transmitter may be malfunctioning, and you should call DCI.

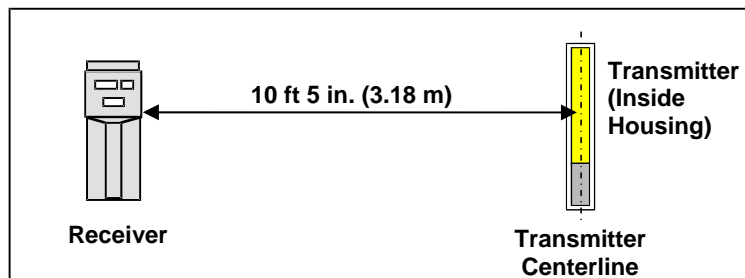

**Determining 1-Point Calibration Signal**

4. Click the trigger one time.
5. The receiver will beep. During the beep, pull in the trigger and hold it.
6. Continue to hold the trigger and watch the countdown (from 5 to 0) displayed in the bottom window. This countdown is accompanied by a chirping sound.
7. When the countdown reaches zero, let go of the trigger.
8. A good calibration will be confirmed by 3 short beeps. Two long tones indicate a failed calibration, which may be due to an inadequate signal from the transmitter or interference.
9. The bottom window should display 120 inches ( $\pm 2$  inches) or 297 cm ( $\pm 5$  cm).
10. Using a tape measure for precise positioning, as in step 3, move the receiver to at least two other locations (e.g., 60 inches [152 cm] and 240 inches [610 cm]) and confirm proper depth/distance readings. Verify that your target drilling depth displays accurately.
11. Note the signal strength for possible later use.

## Confirming Proper Calibration

Check the calibration using a tape measure with the transmitter above ground in the housing. Place the receiver parallel to the housing at a series of accurately measured distances, and verify that the distance displayed in the bottom window corresponds to the distance on the tape measure. If there is a considerable discrepancy between the measured distance and that displayed on the receiver (greater than  $\pm 5\%$ ), then recalibrate.

## 2-Point Calibration Procedure

A 2-point calibration is used when the transmitter is below ground. It is recommended that more than one 2-point calibration procedure be conducted to verify a good calibration. Two procedures are given below—one for newer receivers and one for older receivers (manufactured before 1995 and never upgraded).

### To calibrate (newer receivers):

1. Confirm the lack of background interference by first waiting for the transmitter to fall asleep (10–15 minutes). An acceptable background interference should show a signal strength of less than 150 points (in the top left window with the trigger held in). Make sure that there are no other active transmitters within range of the receiver. (See “Electrical Interference/Background Noise Check” in the Signal Interference Section.)
2. Turn on the transmitter if it is still asleep by rotating the drill string. Position the receiver parallel to and directly over the transmitter; the transmitter’s pitch must be *less than 20%*. The ground surface under the receiver must be relatively solid, flat, and level. The receiver should be displaying pitch, roll, and distance.
3. Hold the receiver level, directly above the transmitter, and at least 12 inches (30 cm) above ground.
4. Click the trigger; you will hear a tone.



5. During the tone, click the trigger again and continue to hold the receiver level and steady. You will then hear 2 beeps followed by a long 6-second tone, indicating that the first calibration point is found.
6. During the 6-second tone, raise the receiver straight up, keeping it level and in the same plane above the transmitter, as high as you comfortably can. Before the 6-second tone ends you must steady the receiver and click the trigger.
7. Continue to hold the receiver in this position until you hear 3 beeps indicating that the second calibration point was found and the calibration procedure is complete.
8. Reset the ultrasonic measurement to zero and check the depth reading while the receiver is sitting on the ground directly above the transmitter. To verify a good calibration, check the depth at two different elevations above ground using the ultrasonics, as described below under “Confirming Proper Calibration.”

**NOTE:** If you hear 2 long beeps, there has been a calibration error, which can be caused by an unstable or weak signal or a failed ultrasonic reading.

### To calibrate (older receivers manufactured prior to 1995 that haven't been updated):

1. Place the transmitter into the drill head housing and place on the ground.
2. Cover the transmitter with a flat surface (e.g., a clipboard, piece of cardboard, plywood, etc.) to provide an ultrasonic response surface.
3. With the trigger held in, position the receiver over the tool using the plus/minus (“+/-”) flip to verify that the receiver is directly over the transmitter’s antenna. Be sure that the signal strength is less than 200 (top left window). If it is more than 200, raise the receiver slightly.

**NOTE:** Mark I Receivers without upgrades do not show 0-999 signal strength. You should see a 7 in the top right window (gain stage 7) and a value of 200 or less in the top left window when performing the 2-point calibration.

4. Follow the instructions given above for calibrating newer receivers beginning with step 4.

### Confirming Proper Calibration

The ultrasonic function can be used to confirm proper calibration when the transmitter is below ground. Check the depth measurement with the receiver held at one position (above the transmitter), then raise the receiver to a new elevation, click the trigger to set the ultrasonics, and note the depth reading. If the depth readings are the same (within 2 inches [5 cm]), then the calibration is good. If the depth readings are not within 2 inches, then the depth/distance readings cannot be relied on and recalibration should be performed.



## Calibrating with Transmitter Underground at Shallow Depth (< 10 feet)

Should recalibration be necessary when the transmitter is below ground at depths less than 10 ft (3 m), it is possible to conduct a modified 1-point calibration procedure. This requires knowing the signal strength of the transmitter in the housing at 10 ft. (You should always note the value of the signal strength when you first perform a 1-point calibration.)

With the transmitter below ground (shallower than 10 ft), place the receiver parallel to the transmitter at a distance to cause the same signal strength as noted during the most recent 1-point calibration. To do this, simply hold in the trigger and move the receiver away from or closer to the transmitter until you see a signal strength reading (top left window) that equals the 1-point calibration signal. Set the receiver on the ground, and complete the 1-point calibration procedure. However, if the transmitter is deeper than 10 ft, it will be necessary to perform a 2-point calibration.

For example, if you noted that the signal strength during the most recent 1-point calibration was 560, then move the receiver parallel to the transmitter to a distance that will result in a reading of 560 and complete the procedure for a 1-point calibration. Remember, this procedure will not work if you are drilling deeper than 10 ft. If this is the case, you will have to perform a 2-point calibration, or, if a spare transmitter is available, you can calibrate to it at a distance equivalent to 560 points of signal (or whatever the signal strength was during the most recent 1-point calibration) and then resume drilling with the same transmitter that is below ground.

When using this modified procedure, you are assuming that the in-ground transmitter is still performing at the same signal strength it was when the most recent 1-point calibration was performed. If the transmitter has been damaged or has overheated, this modified procedure should not be relied upon.

## Using Depth Antenna Plumb Line to Mark Locate Points

To mark the important locating positions (the front negative locate point or FNLP; the rear negative locate point or RNLP; and the positive locate line or PLL) accurately, you must use the vertical axis (plumb line) that runs through the center of the display windows and bisects the depth/locating antennas (see sketch at right). Where this axis intersects the ground is the location that you should mark. This plumb line also serves as the axis around which you can rotate the receiver for confirming the FNLP and RNLP. (For more information, see "Method for Confirming Position" in the Locating Section.)

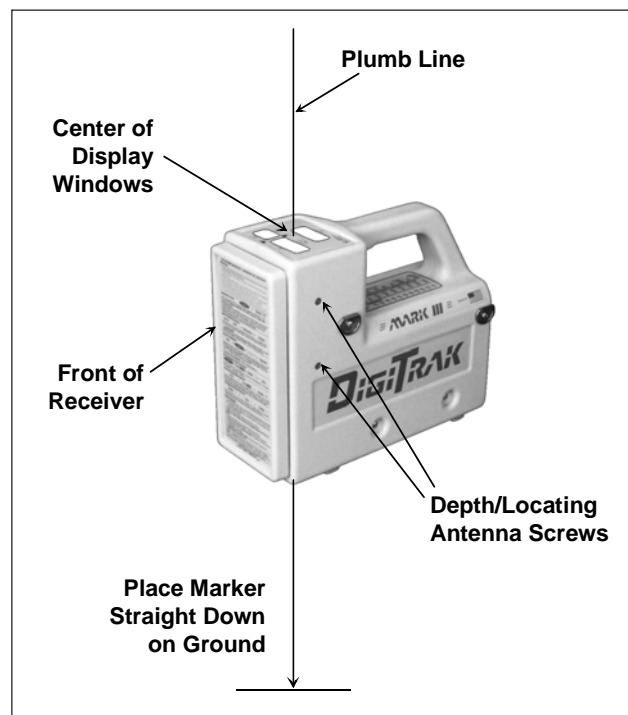

**Depth Antenna Plumb Line**

## Finding Firmware Version

It is possible to determine the firmware version in the receiver. This information is necessary to complete troubleshooting diagnostics with DCI Customer Service by telephone. At start-up the firmware version is displayed briefly in the top left window. If you do not see the firmware version, it is likely that you have an older receiver. If this is the case, to see the firmware version, you must remove and replace the battery in the receiver and then simply hold in the trigger during start-up instead of clicking it, as you would normally do to turn on the receiver. The firmware version will display in the top left window as long as you have the trigger held in. Do not hold in the trigger for more than 12 seconds, however, or you will change the receiver depth measurement units (see “Changing the Depth Measurement Units” earlier in this section). Note that the firmware version will not display the decimal point; therefore, a display of 507 corresponds to firmware version 5.07.

**NOTE:** Receivers with firmware version 3.77 and above are DataLog capable.

## 5.0 Series Firmware Functions

Receivers that have 5.0 series or later firmware will display information differently than pre-5.0 series receivers when the trigger is held in. This firmware is designed to:

- Predict the depth of the transmitter while the receiver is positioned at the FNLP.
- Display the receiver’s rechargeable battery status in percent and voltage remaining (see “On/Off” instructions earlier in this section).
- Turn off the receiver by clicking the trigger in a prescribed sequence instead of removing the battery (see “On/Off” instructions earlier in this section).
- Provide the operator with 3 confirmation beeps after successfully completing the Mark III self-test. If an error is detected 2 long tones will emit and the error code will display in the top left window. (For more information, see “Self-Test for Mark III Receivers” in the Operational Tests Section.)
- Provide a running time meter on the operating hours of the receiver.

### ***Predicted Depth Key Points***

- The 5.0 series firmware provides a predicted depth for the transmitter when it reaches the FNLP.
- The predicted depth is only valid when the operator is standing at the FNLP.
- The predicted depth is never taken at the rear negative locate point (RNLP).
- The predicted depth assumes no substantial change in pitch between the time of the prediction and the time that the transmitter reaches the FNLP.
- The predicted depth number will flash quickly (bottom window) to distinguish it from the depth, which appears as a solid (not flashing) number.
- A solidly illuminated squiggle (“~”) will appear in the bottom window to further distinguish the predicted depth.
- The original slant distance or depth can still be viewed simply by releasing the trigger.
- Pitch updates must occur in order for the predicted depth to be accurate.
- If there is no current pitch, the depth display will not show the predicted depth but instead will show a squiggle when the trigger is held in.

## ***Procedure for Observing the Predicted Depth***

When the receiver (with 5.0 firmware) is at the FNLP and held level with the trigger in, the bottom window will rapidly flash the predicted depth number accompanied by a solidly lit squiggle (“~”); the predicted depth information is also displayed in the bottom window on the remote display. Should the trigger be held in at any other location than the FNLP, the predicted depth in the bottom window will be invalid and should be disregarded. The depth prediction feature requires pitch; should the pitch information become unavailable, the predicted depth display (with trigger held in) will show only the squiggle in the bottom window, and there will be no number for the predicted depth. This feature also requires that the ultrasonic distance be set prior to measuring the predicted depth.

## ***Viewing the Transmitter’s Temperature and the Receiver’s Battery Status in Percent of Remaining Life***

While the trigger is held in, the top left window will display the signal strength (as with pre-5.0 firmware versions) and the top right window will display the transmitter’s temperature in degrees Celsius as a flashing number. When the trigger is released, the top right window will display for 2 seconds the percentage of battery life remaining in the receiver’s rechargeable NiCad battery as 100, 90, 75, 50, 25, 10, 5, or 0, and the top left window will display the transmitter’s battery percentage remaining as 99, 90, 75, 50, 25, 10, 5, or 0. The pitch and roll information will resume 2 seconds after releasing the trigger.

## ***Viewing the Receiver’s Battery Voltage***

The receiver’s NiCad battery voltage is displayed only during the start-up process. The receiver battery voltage is displayed for 2 seconds during initial start-up in the bottom window and is in tenths of a volt, i.e., 155 is 15.5V DC. A fully charged, properly operating NiCad battery is approximately 16.5V to 17.1V DC. At 14.0V DC, the battery is considered discharged.

## ***Off Feature***

To shut the receiver off, click the trigger as if you are taking an ultrasonic measurement. As soon as the unit begins to beep click the trigger 4 or more times (observe 4 or greater in the bottom window). The receiver’s windows will all blank out, indicating the receiver is off. The battery need not be removed to shut off the receiver.

## ***Accessing the Receiver’s Running Time Meter***

The running time meter tracks the operating hours for receivers having 5.0 series and later firmware. To view accumulated running time hours, the receiver must be started with an “on by 4” clicking sequence, as follows:

Place a battery in the receiver. Click the trigger once followed by 4 rapid clicks. The hours will be displayed in the top left window (up to 999), minutes in the top right window, and thousands of hours in the bottom window.

To exit the running time meter display, click the trigger once and the unit will shut off. To restart, click the trigger.

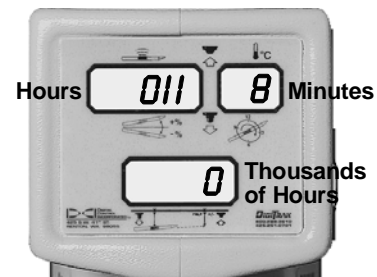

***Running Time Meter Display***

## Transmitter

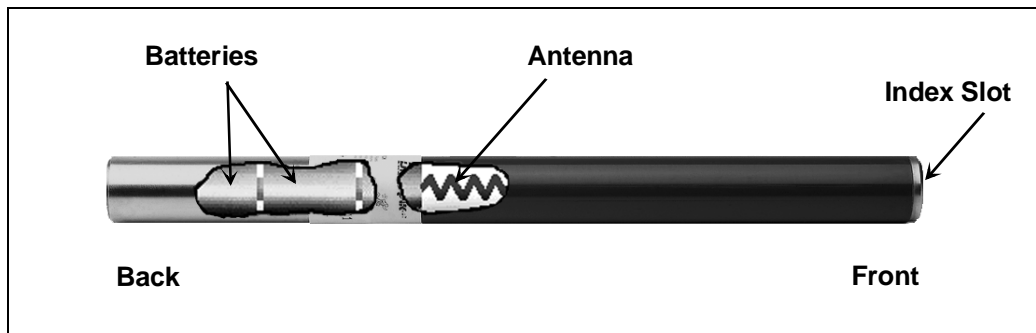

*DigiTrak Transmitter*

A transmitter (also referred to as a sonde, beacon, or probe) is a device that emits electromagnetic signals at radio frequencies and fits inside the tool housing. It transmits information regarding its location, position, and heading. The transmitter emits signals that the receiver “hears” and converts into the information shown in the three display windows. The range of a transmitter depends upon its type. For more information, see the DigiTrak Transmitter Specifications table at the end of this section.

**NOTE:** The range of any transmitter with any DCI receiver is dependent upon the amount of interference at a job site. The range decreases as interference increases.

### How a Transmitter Works

The transmitter emits two types of signals, both at approximately 33 kHz. The first signal is the depth or signal strength. The second signal sends pitch, roll, and battery and temperature status information. The pitch/roll signal has a wider bandwidth than the depth signal and occasionally may be more susceptible to interference. For more information about interference and transmitter signal interruption, see the Signal Interference Section, the Troubleshooting Section, and “Electrical Interference/Background Noise Check” in the Signal Interference Section.

With the trigger released, verify that the transmitter is sending adequate pitch and roll information to the receiver—the top left window of the receiver will flash a squiggle (“~”) every 2.5 seconds. It is important to wait for two consecutive squiggles with the same pitch and roll information before relying on the information to give any steering commands. Waiting assures confirmation of an accurate reading. As the transmitter reaches its maximum range, the squiggles will become less frequent than every 2.5 seconds. For further information on pitch/roll and the squiggle, see the Operational Tests Section (particularly “Transmitter Tests”).

Transmitter pitch is displayed in percent slope as 1% increments or 0.1% increments (if using a sensitive-pitch transmitter) in the top left window of the receiver with the trigger released. For more information see “Sensitive-Pitch Transmitters” later in this section.

Transmitter roll positions are displayed digitally as a whole number from 1 through 12 in the top right window with the receiver's trigger released. The numbers correspond to the hour hand of a clock. At the 12 o'clock position, the transmitter is oriented with the index slot at the top. The tapered or flattened surface of the drill head should be indexed to this position.

## Batteries

All DCI transmitters (except the cable transmitter) are powered by C-cell alkaline batteries (see Transmitter Specifications at the end of this section). The long-range transmitters, including the sensitive-pitch transmitters, have a 4 C-cell option for longer bores. The status of the batteries in the transmitter can be viewed (in percent life remaining) using the receiver's display (see "Battery Status Display" below). The cable transmitter requires an above-ground power supply (see Transmitter Section).

## Temperature Display

Transmitter temperature is displayed in degrees Celsius. Every 4°C increase in the transmitter's temperature will flash for 2 seconds in the top right window of the receiver and the remote display. The receiver will also sound audible tones that increase in intensity as the transmitter's temperature increases. When the remote display has a DataLog module attached, the transmitter's temperature increase tones will be heard at the drill. To manually view the temperature of the transmitter, simply hold in the receiver's trigger; the temperature will flash in the top right window. Receivers with pre-5.0 series firmware will display the temperature in the top right window while the trigger is held in, but it will not flash. To view the transmitter temperature at the drill, see the Remote Display Section.

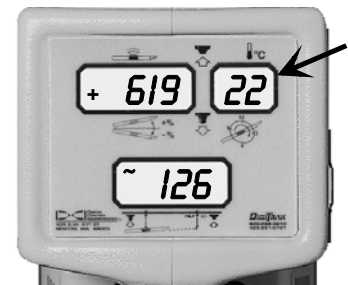

*Transmitter Temperature Display (Flashing)*

## Battery Status Display

The percent of battery life remaining in the transmitter is displayed in the top left window for 2 seconds upon releasing a held-in trigger. The transmitter's battery status in percent remaining life is displayed as 100, 90, 75, 50, 25, 10, 5, or 0. (The receiver's battery status in percent remaining life is also displayed during this 2-second interval in the top right window as 99, 90, 75, 50, 25, 10, 5, or 0.) If the word BAT occurs in the top left window when not viewing the transmitter's battery status, the transmitter batteries must be replaced.

**NOTE:** Neither the temperature nor the battery status will be available until 4 minutes after initial start-up for receivers with 5.0 series or later firmware.

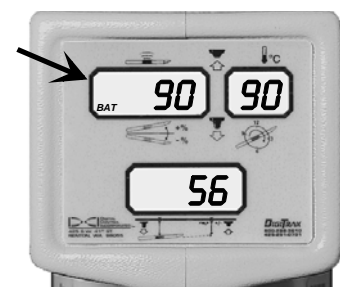

*Transmitter Battery Status in Percent Remaining Life*

## Temperature Overheat

All transmitters have a temperature overheat indicator (temp dot) that has an outer yellow ring with a 1/8-inch (3-mm) white dot in the center. This temp dot is located on the stainless-steel front end cap. On older transmitters, the temp dot is located inside the battery compartment next to the battery terminal.

The temp dot should be white if the transmitter has not been exposed to excessive heat. If the temp dot is silver or gray, it indicates the transmitter has been exposed to heat but not in excess of the specifications. A black temp dot indicates the transmitter has been exposed to temperatures in excess of 104°C (220°F). The transmitter will shut off at about 80°C.

If the transmitter overheats, it may appear to operate normally; however, exposure to excessive temperatures greatly increases the likelihood of inaccurate information and will contribute to premature failure of the transmitter. The warranty does not apply to any transmitter that has been overheated or to any transmitter where the temp dot has been removed. Avoid overheating by practicing proper drilling techniques. Abrasive soils, clogged ports, inadequate mud flow, and poorly mixed mud can contribute significantly to the risk of an overheated transmitter.

The transmitter temperature warnings are listed in the following table. These warnings apply for firmware versions greater than 3.76. Drilling should be suspended when temperatures reach 35°C to permit cooling.

### Transmitter Temperature Warnings

Temperature Range	Warning Signal
14°C and below	No audio or visual warnings.
15°C to 35°C	One double tone with every 4°C increase in temperature.
36°C to 45°C	Two double tones with every 4°C increase in temperature.
45°C to 60°C	Three double tones with every 4°C increase in temperature.
60°C and above	Audible error tones (two long tones) and the bottom window will flash; 1999 may appear when the transmitter shuts down at about 80°C.

## Sleep Mode (Automatic Shutoff)

The transmitter will shut down (go into “sleep” mode) to conserve battery power if it is stationary for 15 minutes. The transmitter sleep mode can be recognized on the receiver as “1999” in the bottom window (no signal). To “wake up” the transmitter, simply rotate the drill string. For more information on 1999 in the bottom window, see the Operational Tests Section, particularly “Transmitter Tests,” and the Troubleshooting Section.

Transmitters manufactured prior to January 1997 have what is called “12 o’clock shutoff.” This means that when the transmitter is in the 12 o’clock position, the transmitter will shut off for 10 seconds and 1999 will be displayed in the bottom window of the receiver.

## Verifying Proper Fit of Transmitter in Housing

Before installing a transmitter into a housing, read the information given below about how the transmitter should fit into the housing. You may then proceed to the installation instructions that follow.

### How Transmitter Should Fit in Housing

The transmitter must fit snugly into the housing. The transmitter has an index slot in the front end cap that fits onto the anti-roll pin (key) in the housing. Wrap the transmitter with tape or O-rings to eliminate

any free space between the transmitter and the side walls of the housing. If necessary, fabricate an “insert” behind the transmitter to ensure a snug fit. When wrapping with tape, be sure that the pitch will not be offset. If more tape is on one end than the other, the transmitter will not be level in the housing. Also, be sure that metal-to-metal contact is avoided.

Before purchasing a new housing, place a transmitter inside and check for a snug fit. Also check that the index slot fits snugly over the key in the housing. If the key is too narrow, the transmitter can rotate and cause damage to the index slot. There are particular “wear patterns” that occur on transmitters that do not fit properly in the housing. If you send a transmitter to DCI for testing, please specify what type of housing you are using.

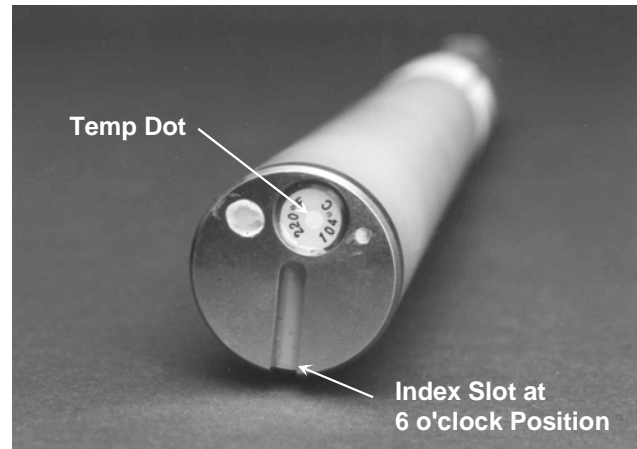

**Front End Cap of Transmitter  
Showing Temp Dot and Index Slot**

Because the transmitter’s antenna is positioned centrally (as shown on the previous page), it is important that the windows or slots in the housing (through which the signal is emitted) are positioned to allow the transmitter’s signal to emit with minimal restriction. The slots must number at least five and have a length of no less than 8 inches (20 cm). These slots must be centered directly over the midpoint of the transmitter. The width of the slots may be as narrow as necessary to maintain housing strength. (Drawings showing the proper slot width, length, and positioning can be obtained by request from DCI.) These slots must not have any filler material containing metal particles, e.g., liquid steel.

### **To install a transmitter in the housing:**

1. Examine the transmitter to verify that there is no moisture inside the battery compartment, that the springs inside the battery compartment have not been permanently compressed, and that the temperature indicator (temp dot) located at the front end of the transmitter is not black.
2. Insert the correct number of C-cell alkaline batteries into the battery compartment with the positive end in first. Place cap over battery compartment and tighten. (See “Batteries” below.)
3. Place the transmitter in the housing with the index slot over the anti-roll pin positioned as discussed above in this subsection. The 12 o’clock position should correspond to the tapered or flattened surface of a typical directional drill head pointed upward.
4. Verify that the transmitter is emitting the appropriate amount of signal (see Operational Tests) and conduct other tests as discussed in the System Operating Instructions Section before you start drilling.

**NOTE:** Place the transmitter in the housing and verify that pitch readings remain the same when the housing is held level and rotated through at least four of the 12 clock positions.

## Locating the Transmitter

The properties of the transmitter's magnetic field enable the receiver to locate the transmitter accurately below ground. The transmitter emits an elliptically shaped field that allows the receiver to locate the transmitter using three specific locations, not just the highest signal. These locations are referred to as the front and rear negative locate points (FNLP and RNLP) and the positive locate line. For more information about locating the transmitter, see the Locating Section.

The transmitter's locate line and points will only be accurately received if the receiver is maintained in a level position. The receiver is ergonomically designed to level itself while easily depressing the trigger.

## Sensitive-Pitch Transmitters

The sensitive-pitch transmitters are designed for gravity sewer installations where pitch must be known in increments smaller than 1%. DCI's sensitive-pitch transmitters operate exactly the same as regular-pitch (1%) transmitters except that the pitch is measured and displayed in one-tenth percent (0.1%) increments.

The transmitter's pitch, which is displayed in the receiver's top left window, does not show the decimal point; therefore a pitch reading of 45 would correspond to a pitch reading of 4.5%.

The maximum pitch that can be measured and displayed with sensitive-pitch transmitters is 10%. A reading of 10% will correspond to a display of 100 in the receiver's top left window. If the launch or exit portions of the borepath exceed 10%, it may be preferable to drill those sections using a regular-pitch transmitter and then use a sensitive-pitch transmitter for the remainder.

### Tips for drilling with a sensitive-pitch transmitter:

1. Plan the borepath and position the drill rig so that the launch and exit profiles are gently sloped.
2. Using a level test surface, verify that the pitch does not fluctuate as the transmitter is rolled through all 12 clock positions. If it does, make note of the variation.
3. Perform the same test with the transmitter in the housing. This will indicate whether the transmitter is being held level in the housing.
4. Take pitch readings with the transmitter positioned at 9 or 3 o'clock, after the tool has been pulled back a few inches from the front of the tunnel, to obtain greatest accuracy of sensitivity.
5. Verify that the tool is at the correct depth and pitch before drilling critically sloped portions of the borepath. Incorrect initial positioning can result in exceeding the steering capabilities of a drilling tool. If the drill tool is not correctly positioned at the beginning, this error can compound and/or you may not be able to steer the tool to recover.

## Transmitter as an Inclinometer

It is possible to use the transmitter as an inclinometer to measure the slope of the ground above the borepath. This can be useful if the borepath is targeted at a constant depth below the surface. Simply match the transmitter's pitch to the carefully measured slope of the ground and the depth should be constant.



## Serial Numbers

All transmitters are identified by a serial number stamped in the metal battery compartment near the plastic/stainless steel contact.

**NOTE:** When calling DCI Customer Service be prepared to supply the serial number.

## Specifications

The specifications given below assume the use of the latest model (Mark III) of the DigiTrak Receiver. All Mark III Transmitters operate at a frequency of approximately 33 kHz. Pitch updates occur every 2.5 seconds, and roll updates occur every 0.25 second. All transmitters revert to sleep mode after 15 minutes except the cabletransmitters, which are turned off by disconnecting the above-ground battery source. All transmitters also transmit information regarding transmitter temperature and estimated battery life remaining.

### DigiTrak Transmitter Specifications

Model / Color	Type of Transmitter	Length x Diameter	Signal Range*	Battery Type	Temp. Rating	Weight
DS Blue	Short Range	8 in. x 1.00 in. 20 cm x 2.54 cm	15 ft 4.6 m	1 AA-cell alkaline 12 hours awake 50 hours sleep	180°F 82°C	8.4 oz 240 g
DT Yellow	Standard Range	15 in. x 1.25 in. 38 cm x 3.125 cm	40 ft 12.2 m	2 C-cell alkaline 30 hours awake 200 hours sleep	220°F 104°C	1.4 lb 635 g
DX Red	Long Range	15 in. x 1.25 in. 38 cm x 3.125 cm	70 ft 21.3 m	2 C-cell alkaline 20 hours awake 200 hours sleep	220°F 104°C	1.4 lb 635 g
D4X Red	Long-Range w/ Extended Life	19 in. x 1.25 in. 48 cm x 3.125 cm	70 ft 21.3 m	4 C-cell alkaline 40 hours awake 400 hours sleep	220°F 104°C	1.85 lb 840 g
D4XP Magenta	D4X w/ Sensitive Pitch (0.1%)	19 in. x 1.25 in. 48 cm x 3.125 cm	70 ft 21.3 m	4 C-cell alkaline 40 hours awake 400 hours sleep	220°F 104°C	1.85 lb 840 g
DXP Magenta	DX w/ Sensitive Pitch (0.1%)	15 in. x 1.25 in. 38 cm x 3.125 cm	70 ft 21.3 m	2 C-cell alkaline 20 hours awake 200 hours sleep	220°F 104°C	1.4 lb 635 g
DCX Green	Cable Transmitter	15 in. x 1.25 in. 38 cm x 3.125 cm	140 ft 42.7 m	12V to 28V DC cable power	180°F 82°C	1.2 lb 545 g
DCP Magenta	DC w/ Sensitive Pitch (0.1%)	15 in. x 1.25 in. 38 cm x 3.125 cm	140 ft 42.7 m	12V to 28V DC cable power	180°F 82°C	1.2 lb 545 g

\*Depth/distance accuracy is  $\pm 5\%$  absolute.

## Remote Display System

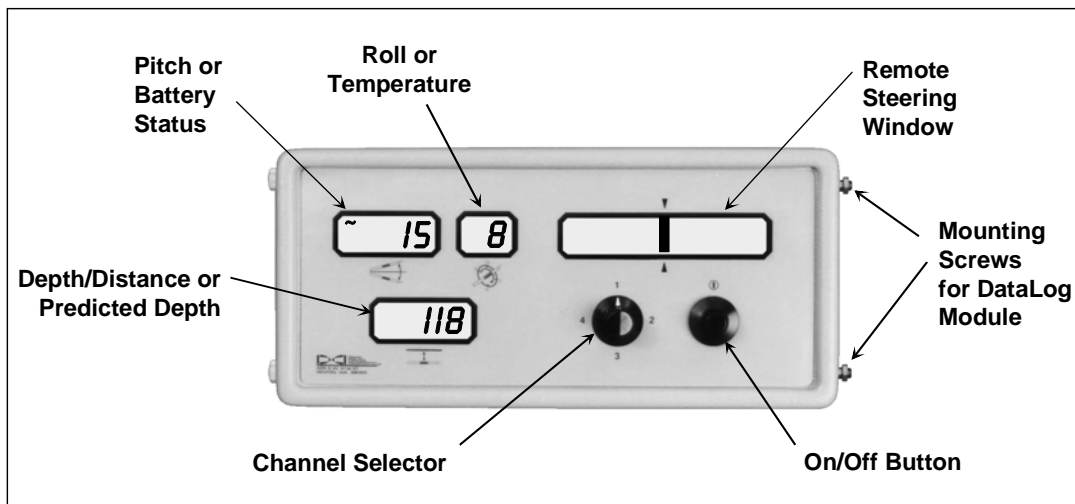

**Remote Display Unit**

The DigiTrak Remote Display unit is typically positioned where it will be readily visible by the drill operator. The remote display uses telemetry to display some of the information displayed by the receiver. The remote display can also be used for remote steering when walkover tracking is not possible. The left side of the remote display's panel is identical to the receiver's display panel. The long window to the upper right is used for remote steering (see below).

The remote display will show the drill operator the transmitter's pitch, roll, depth, temperature, battery status, and predicted depth. It will not display signal strength or the plus/minus ("+/–") symbols.

The receiver must have remote capability to send a signal to the remote display; receivers with this capability are identified by a large orange arrow below the battery door. All receivers can be upgraded to remote capability by DCI. The maximum separation between the receiver and the remote display can range up to about 4000 ft (1220 m) depending upon interference and topographic features.

The DigiTrak System uses ultrahigh-frequency telemetry to communicate between the receiver and the remote display. Both the receiver and the remote display must have the same type of telemetry to communicate properly.

## On/Off and Setting the Channel

To turn the unit on, place a fully charged DigiTrak battery pack into the battery compartment, terminal end in first, then push the black button on the front of the display panel.

Select one of the four channels. Note that channels 1 and 3 use one frequency, and channels 2 and 4 use a second frequency. Be sure to change the channel selection on the receiver to match that selected on the remote display (see “Changing the Receiver’s Channel Setting” in the Receiver Section).

**NOTE:** A zero (0) on the receiver indicates that the receiver’s telemetry is shut off and no signal will be sent back to the drill, which will result in “dashes” across the three display windows on the Remote. Setting the receiver to channel 0 may be useful for conserving receiver battery power.

The transmitter information on the remote display will be the same as that at the receiver, except the Remote will not display signal strength nor the “+/-” locating symbols. The remote display will continue to display pitch, roll, and distance along with the flashing squiggle (“~”) in the top left window, indicating that updates are being received. You should always wait for two consecutive updates with the same pitch/roll information before making a steering action.

The remote display has no automatic shutoff function. To turn the unit off, push the on/off button. Never ship a remote display or receiver with a battery in the battery compartment.

## Transmitter Temperature and Battery Status

Remote displays with firmware versions of 3.9 or later automatically display the transmitter’s temperature and battery status in the top right window for 2 seconds when a 4°C temperature increase occurs. The transmitter’s temperature and battery status can also be viewed on command by turning the Remote off and then back on. Remotes with older firmware versions (3.8 or earlier) will display transmitter status automatically every 30 seconds but not at start-up. The drill operator will hear temperature increase tones when a DataLog module is attached to the remote display.

For more information on transmitter temperature display intervals, see firmware update information on DCI’s web page located at [www.digitrak.com](http://www.digitrak.com). To determine the remote display unit’s firmware version, see “Finding Firmware Version” below and, for the receiver, see “Finding Firmware Version” in the Receiver Section.

## Remote Steering

Remote steering is used to cross streams and roadways or other inaccessible areas when it is not possible to walk over the transmitter. To initiate the remote steering capability, the receiver is placed in front of the transmitter as the “target.” The distance the receiver can be placed ahead is limited by the range of the transmitter and interference.

With the transmitter powered up and in the housing ready to drill, walk with the receiver (powered up and trigger held in) on the surface over the intended borepath to the “target” location. Verify that the receiver displays at least 250 points of signal at target location. Place the receiver on its side so that the orange arrow on the receiver points toward the ground. The target point on the receiver is the center point between the two depth/locating antenna screws. The receiver’s front panel should face the drill. To position the receiver properly, it is important to pivot the receiver using the center point between the two antenna screws as the axis of rotation. When the receiver is properly pivoted on this axis, the vertical bars (indicating the transmitter’s position) will line up with the two triangles (indicating the target) in the center of the remote steering window. When the receiver is in its target position, its top surface must be level. If necessary, place shims under the receiver to level it.

On the remote steering window, the receiver (target) is represented by two triangles, one above and one below the window; the transmitter is represented by a vertical bar in this window (see photo on next page). If the bar is to the right of the triangles, the tool will need to be steered to the left so that the steering indicator is lined up with the triangles; if the bar is to the left of the triangles, the tool will need to be steered to the right.

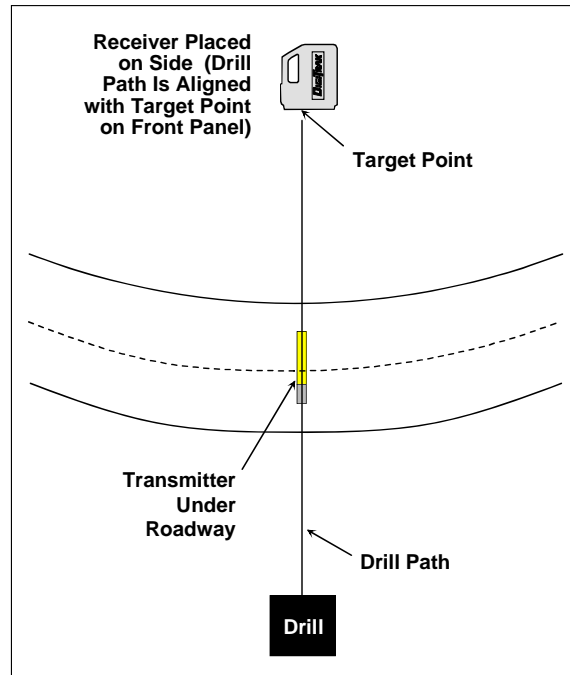

**Setting up DigiTrak Receiver for Remote Steering**

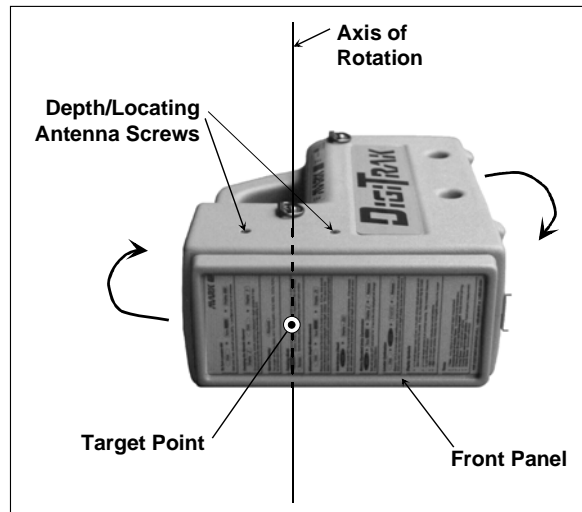

**Using DigiTrak Receiver for Remote Steering**

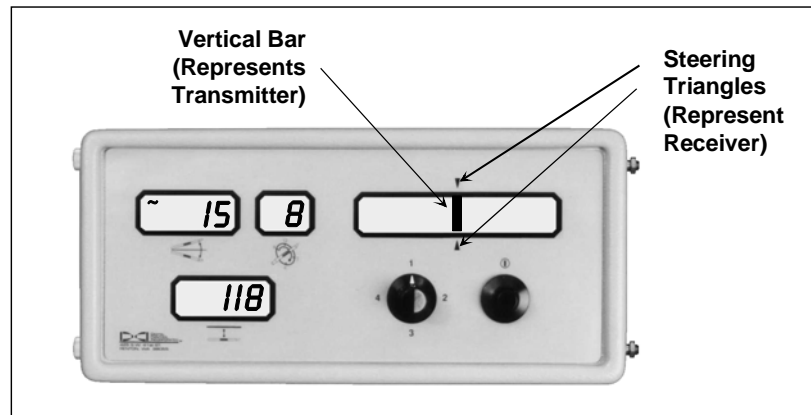

***Align Vertical Bar (Transmitter) with Triangles (Receiver) in Remote Steering Window to Steer Tool***

As the transmitter approaches the target (receiver), the FNLP will pass underneath and go past the receiver. At this point, the remote steering is no longer accurate and the receiver must be moved to a new farther-out location. The distance between the transmitter and the FNLP is dependent upon the depth and pitch of the transmitter and the topography. When the pitch of the transmitter is 10% or less and the ground is parallel to the transmitter, the FNLP is ahead of the transmitter by approximately 0.7 times the transmitter depth. As an example, if the transmitter is 8 ft (2.4 m) below ground, the FNLP will be approximately 5.6 ft (1.7 m) in front of the transmitter (8 ft x 0.7 = 5.6 ft).

Because the receiver has not been used as a walkover tool to track the depth of the transmitter during remote steering, it will be necessary to calculate the depth based on the pitch information. For more information about calculating the depth based on pitch, see "Running Off Pitch or Calculating Depth from Pitch" in the Locating Section.

## Finding Firmware Version

The firmware version installed in the remote display can be identified as follows:

1. Place a battery pack in the unit.
2. Click the "on" button.
3. The firmware version will be displayed in the top left window for 2 seconds. When the firmware version is displayed, the decimal point will not be shown. For instance, firmware version 3.77 will be displayed as 377.

After releasing the button, the unit will complete start-up and then be ready for use.

## DataLog Capability

Current Mark III Remote Displays have two metal studs protruding from the right side of the display case for optional DataLog module attachment. The DataLog module also has a speaker, so the drill operator hears the transmitter temperature increase tones and logging tones. Call DCI if you are interested in obtaining more information on the DataLog Mapping System.

## **Battery Charger**

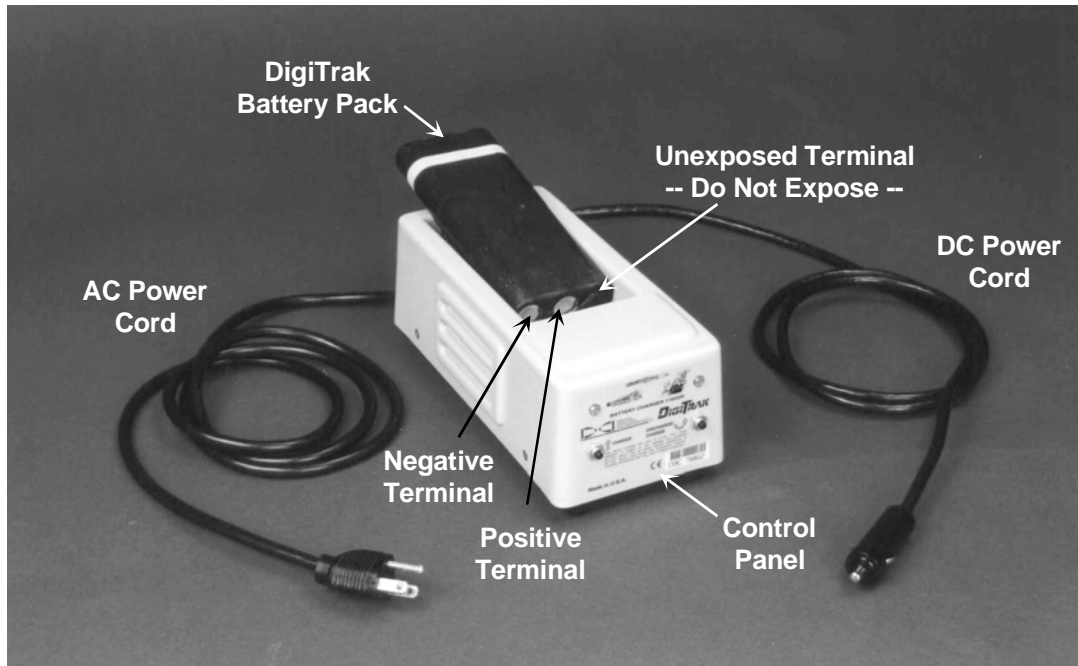

**DigiTrak Battery Charger**

Both the DigiTrak Receiver and the Remote Display use a DigiTrak rechargeable NiCad battery pack that is provided with the system together with a DigiTrak Battery Charger. The battery pack should be fully discharged before recharging; this is known as conditioning the battery.

The battery charger can be powered from AC or DC and is equipped with a conditioning or discharge cycle designed to remove the “memory effect” from the battery. The charger will operate from any AC voltage (wall outlet) between 85V and 240V without modification (you may need to convert the plug). This allows the same battery charger to be used in many different countries. The battery charger is also equipped with an automotive cigarette lighter adapter for 12V or 28V DC charging. The older-style chargers do not have a conditioning cycle, so the batteries should be used until fully discharged before they are put in the charger to be recharged. See “Conditioning a Battery Manually” later in this section for instructions.

NiCad batteries can develop a memory. This condition is caused by repeatedly charging a battery before it has been completely discharged. If this occurs, it will appear to the user that the battery has a shorter life. Batteries with this condition can be restored to normal function by using the conditioning cycle. It is not necessary to condition a battery if it has been completely discharged through normal use. Excessive conditioning does not improve battery performance and only serves to shorten battery life. If a battery fails to improve after two or three conditioning cycles, it should be replaced.

The voltage on a fully charged battery is between 16.5V and 17.1V. A battery is considered discharged at 14.0V.

Only two terminals are exposed on the DCI NiCad battery pack, although a third terminal appears to be available. If the third terminal accidentally becomes exposed, do not try to charge the battery pack or you may damage the battery charger. Such a battery can also damage the remote display or receiver. A damaged battery pack will require replacement.

## Charging a Battery

**NOTE:** Only charge DigiTrak NiCad batteries in the battery charger. Charging or using other types of batteries may damage the charger, the receiver, or the remote display and will void the warranty.

1. Plug the charger into either a wall outlet or the cigarette lighter of a vehicle.
2. Place a discharged battery into the charger with the terminal end making contact with the springs. The red light on the left will illuminate, indicating that the unit is charging.
3. The battery will take between 20 minutes and 2 hours to charge, depending on the extent of discharge. When the charging cycle has been completed, the green light on the right will illuminate, indicating that the battery has completed the charging cycle and is ready for use.
4. If the battery is left in the charger, a trickle charge cycle will continue to “top off” the battery and maintain the optimum battery level while the battery is in the charger. The green light will stay illuminated, indicating the battery is fully charged and ready for use.

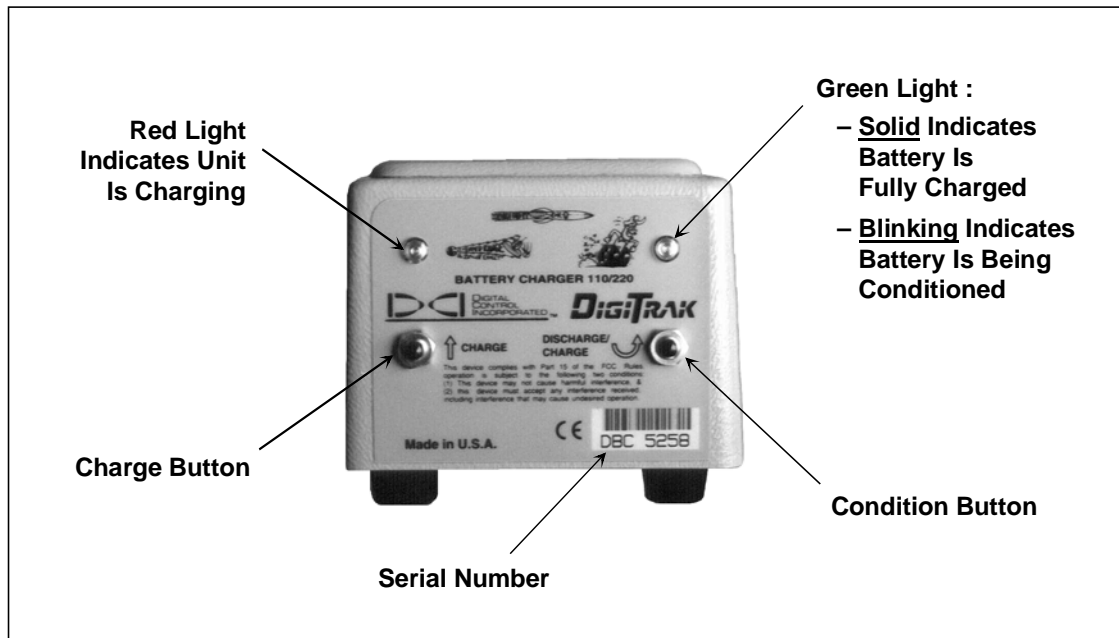

**Battery Charger Control Panel**

## Conditioning a Battery in the Charger

1. Place the battery into the charger.
2. Press the right button on the charger (marked with a curved arrow). The red light on the left will go out and the green light on the right will start to blink. This indicates that the battery is being conditioned. The conditioning cycle may last for up to 7 hours, depending on the remaining charge in the battery.
3. When the conditioning cycle is completed, a charging cycle will automatically start, indicated by the red light turning on and the flashing green light going out. The battery is discharged to 12V before charging begins.
4. When the battery has reached full charge, the green light will illuminate indicating a fully charged battery is ready.

## Conditioning a Battery Manually

To condition a DCI battery pack, you simply need a low-wattage 12V light (such as a small automotive side light or an interior light bulb) and electrical wires to connect the battery pack to the light as shown.

The length of time required to condition a NiCad battery manually can range from 1 to 7 hours. The battery should not be discharged beyond 12V. Measure the voltage across the light to confirm the battery is discharged to no lower than 12V.

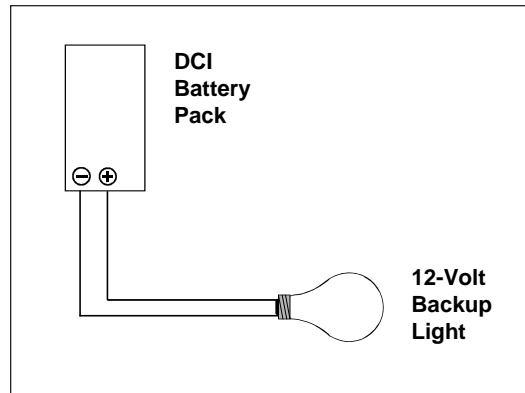

*Setup for Discharging a Battery Manually*

## Indicator Lights and Meanings

Action / Meaning	Red Light	Green Light
Unit is off or no battery is in unit	Off	Off
Unit is charging a battery	On	Off
Battery is charged	Off	On
Unit is discharging a battery	Off	Blinking
Unit is malfunctioning	Blinking	Off

**NOTE:** If a battery is left in the charger during a power interruption, the red or green light may flash and the battery will begin to discharge on its own. Simply remove and replace the battery pack after the power has resumed.



## **Notes**

# ***System Operating Instructions***

## **Start-up Procedure**

1. Ensure that the transmitter has fresh C-cell alkaline batteries installed and place the transmitter inside the tool housing.
2. Click the receiver trigger, located under the handle. All the displays will illuminate, and a tone will sound.
3. Ensure that the receiver's battery pack does not indicate low battery power (bottom window would display "BAT").
4. Complete electrical interference check (see Operational Tests Section).
5. Verify that the receiver is displaying pitch/roll updates by watching the squiggle ("~") in the top left window. The squiggle should briefly flash every 2.5 seconds.
6. Roll the transmitter housing on a flat surface (with the transmitter inside) to verify that the transmitter's clock positions match the display in the top right window.
7. Lay a tape measure between the transmitter in the housing and the receiver.
8. Complete the calibration procedure (see "Calibrating the Receiver" in the Receiver Section).
9. Verify that the distance displayed in the bottom window matches the distance on the tape measure at varying distances, in particular 1.5 times the target depth for the intended borepath.

## **Shutdown Procedure**

The receiver will automatically shut itself off after 15 minutes of no signal received. To turn the unit off when a signal is present, click the trigger once and, during the tone, quickly click 4 times. All windows will blank out, indicating that the unit is off. To turn off a pre-5.0 series firmware receiver when a signal is present, you must manually remove the battery. (For more information on the 5.0 series firmware and operating/display differences, see "Clicking vs. Holding the Trigger" and "5.0 Series Firmware Functions" in the Receiver Section.)

## **Moisture and Temperature Avoidance**

The DigiTrak Receiver and Remote Display are rainproof but not waterproof and should be protected from immersion or excessive splashing. In addition, condensation inside the equipment can occur if the equipment is subjected to repeated large temperature changes. Avoid sudden, large temperature changes to protect from condensation buildup. Placing a cold beverage can on the display window will confirm the presence of moisture if there is a ring of droplets after the can is removed.

Contact DCI at 425-251-0559 or 800-288-3610 for field "drying" technique.

## Optimal Operating Temperatures

The minimum operating temperature for the DigiTrak locating equipment is -4°F (-20°C). All battery-operated equipment is prone to “capacity loss” in cold temperatures. Excessively cold temperatures can result in slow display response and increased measurement errors. The maximum temperature for receivers and remote displays is 176°F (80°C). Operation in direct sunlight can cause temperatures greatly in excess of the air temperature. The maximum temperature for transmitters varies between 180°F (82°C) and 220°F (104°C) depending on the model—see Transmitter Specifications at end of Transmitter Section.

## General Maintenance

Please observe the following general maintenance requirements:

- Turn off all equipment when not in use. Remove the batteries from the receiver and/or the remote display when done using the equipment.
- Do not ship any DigiTrak locating equipment with the batteries inside. Always remove the batteries from the equipment before shipping.
- Do not use chemicals to clean the transmitter.
- Do not leave the transmitter in the housing overnight.
- Store the DigiTrak equipment in cases, away from heat, cold, and moisture. Perform tests to confirm proper operations.
- Do not disassemble or attempt to repair DigiTrak locating equipment.
- Contact DCI at 425-251-0559 or 800-288-3610 or visit our web site at [www.digitrak.com](http://www.digitrak.com) to stay current with the latest innovations.

## Signal Interference

Before drilling (preferably before bidding on a project) the interference potential at your site(s) should be evaluated. Interference can reduce the transmitter's range or cause variable readings and possibly result in job slowdowns. Interference comes from two different types of sources: active and passive.

**Active interference** is also known as electrical interference or noise and can have varying effects upon the DigiTrak locating equipment. Most electrical devices emit signals. Because DCI receivers have two types of antennas in them (depth and roll/pitch), it is possible to have interference that affects one or both signals. Some examples of active interference are traffic signal loops, buried dog fences, cathodic protection, radio communications, microwave towers, cable TV, fiber-trace lines, utility data transmissions, security systems, power lines, and phone lines.

**Passive interference** sources (listed below) can reduce the amount of signal received or reradiate the transmitter's signal. This can cause erroneous depth readings or, in extreme cases, no signal, i.e., "1999" in the bottom window. In addition, the FNLP and RNLP (discussed in the Locating Section) may be affected. Some examples of passive interference are:

- Metal (pipes, rebar, trench plate, chain-link fence, engine blocks, etc.) – Metal acts as an antenna and can therefore draw the receiver to erroneous locations.
- Saltwater – Saltwater affects conductivity and can contribute to signal degradation. Before drilling in saltwater or brackish water, conduct a range test in the salt or brackish water to determine the amount of signal loss (see "Transmitter Salt Water Range Test" in the Operational Tests Section). Depth error will be increased and roll/pitch range will be reduced. A 2-point calibration can help reduce the error (see "2-Point Calibration Procedure" in the Receiver Section).
- Conductive earth – Drilling through formations with high metal ore content can degrade the transmitter's signal and cause depth errors and reduced roll/pitch range. Again, a 2-point calibration can be used to reduce the depth error (see "2-Point Calibration Procedure" in the Receiver Section).

To install your product accurately and safely, the location of every below-ground structure proximal to the intended borepath should be confirmed by potholing. This task is the first step in familiarizing yourself with the interference potentials near the intended borepath. The next step is to conduct an electrical interference/background noise check, as described below.

### Electrical Interference/Background Noise Check

An electrical interference check will familiarize you with your site conditions and help determine potential locations along the borepath where the transmitter's signal may encounter interference. Things that can cause interference include the following: traffic signal loops, cable TV, saltwater, microwave towers, utility data transmissions, power lines, fiber-trace lines, security systems, invisible (buried) dog fences, large metal objects, rebar, and cathodic protection.

There are two steps to the electrical interference/background noise check. The first step takes one person; the second step requires two people.

1. With the transmitter off, test the amount of noise the receiver hears by holding in the trigger and walking the borepath from the launch to the exit location. Watch the signal strength (top left window) and note the locations where the signal strength changes. Typically, a reading greater than 150 indicates background noise that may interfere with the magnitude and shape of the transmitter's magnetic field lines and therefore alter the depth/distance readings and the locate points and line.
2. At the exit end of the borepath, install batteries in the transmitter to activate it. Then have one person carry the transmitter along the borepath back to the drill while the other person walks in parallel at a distance approximately one and one-half (1.5) times the target depth of your installation while carrying the receiver. Do not hold in the trigger on the receiver; simply watch all the windows for any changes in the transmitter's information. Verify that the squiggle ("~") in the top left window is flashing every 2.5 seconds (indicating you are receiving pitch/roll updates). In particular, note any locations where the display information inexplicably changes or where the pitch and roll updates become infrequent.

See suggestions for dealing with interference in the following section.

## Suggestions for Dealing with Interference

Every job site warrants an electrical interference/background noise check no matter how remote and interference-free your job site appears to be.

If pitch and roll (along with transmitter battery and temperature status) suddenly stop updating, it is sometimes possible to recover the signal by walking away from the transmitter in several directions, staying within the published range. The objective is to move away from the interference source.

Another solution is to use a stronger-signal-strength transmitter. For example, if using a yellow standard-range DT Transmitter, then try a red long-range DX Transmitter, and if you're using a red DX Transmitter, then try the Cable Transmitter. (See the Cable Transmitter Section.)

# Operational Tests

## Self-Test for Mark III Receivers

Mark III Receivers have the capability of completing a diagnostic self-test to confirm proper operation. This test must be conducted without a transmitter and in an interference-free environment. The self-test procedure is conducted at start-up by clicking the trigger in a specific sequence.

1. Place a fully charged DigiTrak battery into the receiver and click the trigger once.
2. At the tone, quickly click the trigger 3 times (observe the number 3 in the bottom window). The test takes approximately 15 seconds to complete.
3. If no problem is detected, the receiver will sound 3 tones, and turn itself off.
4. If the receiver detects a problem, it will display an error code in the top left window accompanied by 2 long tones.
5. An error code of "001" indicates high background noise; move to an interference-free area and conduct the self-test again.

For assistance with troubleshooting an error code call DCI.

## Receiver Balance Check

If the receiver appears to be exhibiting a consistent left or right error, it is possible that the antennas in the receiver are out of balance. It is also possible to find the transmitter further to the left or right if you use only signal strength to locate the transmitter or if there is an interference source within proximity. The transmitter's location (depth and left/right position) should always be determined using the front and rear negative locate points, not relying solely on peak signal.

To determine if the receiver's antennas are in balance, complete the following test:

1. Place the transmitter on the ground and step out in front (or behind) about 10 to 12 ft (3 to 3.7 m) away and a little to the left or right side of the axis line that extends from both ends of the transmitter, as shown in the drawing.
2. Hold the receiver perpendicular to the transmitter with the trigger held in.

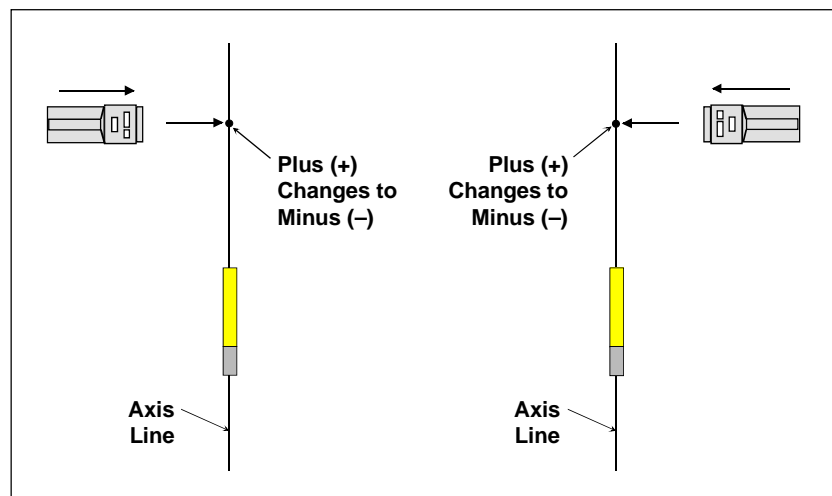

**Receiver Balance Test** – Make sure “+” changes to “-” on same line coming from both directions.

3. Walk toward the axis line and watch for the plus (“+”) sign in the top left window to change to a minus (“-”) sign. Note this location.
4. Continue past the axis line, then stop and turn the receiver 180° around so it is facing in the opposite direction. Walk back toward the axis line from this opposite side and find the location where the “+” changes to a “-”.
5. These two locations should be in the same place and lie on the axis line. If not, call DCI for assistance.

## Receiver Gain Test

Another test to confirm that the receiver is displaying the depth information correctly is to conduct a gain test. This is a check of the receiver’s scaling system for depth and is similar to the old “walkie talkie” gain. To complete the gain test, you will need an active transmitter, a tape measure, and the receiver.

1. Run the tape measure from the side of the transmitter (in or out of a drilling head) as if preparing for 1-point calibration (see “Calibrating the Receiver” in the Receiver Section). The tape measure should extend out to the transmitter’s maximum range (see “Specifications” table in the Transmitter Section for the maximum range ratings).
2. Place the receiver parallel to and 5 ft (1.5 m) from the transmitter and note the depth (do not hold in the trigger).
3. Move the receiver 10 ft (3 m) away and note the depth.
4. Continue to check the depth as the receiver is moved away from the transmitter in 5-ft (1.5-m) increments until maximum range is reached (“1999” will appear in the bottom window).
5. The final part of the gain test is to move the receiver back toward the transmitter at the same 5-ft increments and verify that the depth information matches.

The depth readings at the 5-ft (1.5-m) increments should be the same whether the receiver is moved toward or away from the transmitter. If they are significantly different, contact DCI for technical assistance.

## Transmitter Tests

- **Temperature Indicator** – Verify that the temperature indicator (temp dot) located at the front end of the transmitter is white. Older transmitters have the temperature indicator located inside the battery compartment, next to the battery terminal. If the temp dot has changed from white to black, then the transmitter has been exposed to temperatures in excess of 220°F (104°C); for older models, the maximum temperature is 180°F (82°C). Exposure to high temperatures may cause the transmitter’s operation to be affected. A transmitter that has been overheated may appear to work fine; however, it should be considered unreliable. The limited warranty on a transmitter is void if the transmitter has been overheated or if the temperature indicator has been removed.
- **Moisture** – Verify that there is no moisture inside the battery compartment and that the springs inside the battery compartment have not been permanently compressed.

- **Defective Transmitter** – With the transmitter and receiver on, place the transmitter against the receiver (long side of transmitter parallel to long side of receiver) while holding in the trigger. If you see anything less than 999 in the top left window and 000 in the bottom window, it is likely that there is a broken antenna in the transmitter. You will need a new transmitter. Readings of 999 and 000 indicate that the transmitter is sending the appropriate amount of signal when held close to the receiver (12-20 inches [30-51 cm] for a yellow transmitter and 20-40 inches [50-100 cm] for a red transmitter); this is called signal saturation.

**NOTE:** Older transmitters have an LED in the front end cap near the index slot indicating that the batteries are loaded properly and that the transmitter is powered up.

- **Signal Strength** – Verify the appropriate amount of signal strength at varying distances. The signal strength indicates the power output of each transmitter. The signal strength is tested by placing the receiver and transmitter (inside the housing) parallel to one another at varying distances while holding in the trigger. If the transmitter is within  $\pm 60$  points of the chart below it is considered to be within specifications (the  $\pm$  variance is to allow for different types of housings, which may affect the amount of signal emitted through the slots of the housing).

**Transmitter Signal Strength Values\***

Transmitter Color	Distance				
	5 ft (1.5 m)	10 ft (3 m)	15 ft (4.5 m)	20 ft (6 m)	30 ft (9 m)
Blue	600	420			
Yellow	740	560	455	380	275
Red	800	620	515	440	335

\*The signal strength values may vary by up to 60 points depending on the type of housing being used.

**NOTE:** From day to day, the signal strength of the same transmitter in the same housing with the same receiver at 10 ft (3 m) should be the same. If not, it may indicate interference or a bad transmitter. Any variation in signal strength will affect receiver calibration and result in erroneous depth/ distance readings.

- **Pitch/Roll Updates** – Verify that the squiggle (“~”) in the top left window flashes every 2.5 seconds. This squiggle indicates that pitch/roll updates are being sent from the transmitter and heard by the receiver. If the squiggle is not appearing consistently, then you should not rely on the pitch/roll readings. As the maximum distance range is reached, the updates will become less frequent. To determine whether or not a transmitter is sending adequate updates, place the receiver 20 ft (6 m) from the transmitter (in the housing) and count the number of squiggles in a 30-second period. If there are six or more squiggles, then adequate transmitter signal is being received by the receiver. If not, check for interference, verify the transmitter’s signal strength, or call DCI Customer Service at 425-251-0559 or 800-288-3610 for assistance in determining the source of the problem.
- **Roll/Clock Check** – Verify each clock position by slowly rotating the transmitter on a flat surface.
- **Pitch/Inclination Check** – Confirm that the pitch readings change by moving the transmitter from positive to negative pitches/inclinations.



- **Battery Life** – Verify the housing slots (windows) are properly aligned over the transmitter’s antenna. If the battery life of a transmitter seems to be shorter than that noted in the specifications provided in the Transmitter Section, it could be due to battery arcing, which can occur in hard drilling conditions. transmitter batteries arc when they bounce/slam into each other, losing contact intermittently. This usually results in a permanently compressed positive contact and, therefore, no contact or signal. It is also possible for a defective transmitter to draw more current than it should, resulting in shorter battery life. Perform the following test to determine if a transmitter is drawing too much current.

### Current Draw Test:

1. Assemble the necessary equipment for the test: Transmitter, C-cell alkaline batteries for transmitter, housing, current/amp meter (0-500 mA).
2. Place the batteries in the transmitter (leave off the battery cap) and place the transmitter in the housing.
3. Set the amp meter to DC amps (symbol looks like mA  $\overline{\sim}$  on the amp meter) and plug the positive (red) connector wire into the highest setting location on the meter (10 A).
4. Place the meter’s negative probe into the transmitter battery compartment making contact with the end of the battery while placing the red probe onto the battery housing of the transmitter. It may be necessary to roll the housing to “wake up” the transmitter. The meter displays amps, not milli-amps, so be sure to convert by moving the decimal three places to the right (for example, a reading of 0.104 A would be 104 mA). The table below shows the target current ranges in milli-amps for properly functioning transmitters.

Transmitter Model	Average Current (mA)
DT (Yellow, Standard Range)	100 ± 20
DX (Red, Long Range)	220 ± 20
D4X (DX w/ Extended Life)	110 ± 20

## Transmitter Salt Water Range Test

This test should be performed when there is a question about salinity affecting the transmitter’s range. The test requires rope, a measuring tape, the receiver, an active transmitter, and a platform to lower the transmitter into the water.

1. Attach the rope to the transmitter in a “sling-like fashion” so that the transmitter will remain level as it is lowered.
2. Secure the measuring tape to the rope so that the depth below the water surface can be observed.
3. Gradually lower the transmitter while observing the depth on both the measuring tape and the receiver’s bottom window (trigger released). Also observe the squiggle in the top left window, is it flashing every 2.5 seconds indicating proper pitch/roll updates are being received? This test can be difficult to conduct in a swift current.
4. If testing in tidal areas, conduct the test under the same tidal conditions that will be encountered during drilling. Incoming tides increase the salinity of brackish water and cause greater interference.

## Transmitter Battery Tests

- The design of the windows/slots in a housing can greatly affect the transmitter's battery life, especially on the red long-range DX Transmitters. The windows must be a minimum of 8 inches (20 cm) long and line up longitudinally along the drill housing, directly above the center of the transmitter. (Drawings are available upon request.) A minimum of five slots, equally spaced around the diameter of the housing, are required. Ensure the slots are not filled with any material containing metal particles, e.g., liquid steel.
- The batteries used with DigiTrak Transmitters must be alkaline. Check the manufacturing date to ensure freshness when purchasing or using any batteries. Ray-O-Vac and Kodak brand alkaline batteries are not suggested for use in DigiTrak equipment. *Consumer Reports* has shown that these batteries do not have as long a life as the others. Alkaline batteries normally have a 5-year shelf life. Rechargeable batteries should not be used because of limited capacity, and the remaining battery life readings will not be accurate.
- Batteries can be tested on a load-inducing battery tester, e.g., Radio Shack Model 22-096A. A voltmeter will not provide an accurate measure of the life remaining.
- Make sure the battery connections in the transmitter are kept clean, ensuring good contacts with the batteries. Check that the springs inside the battery compartment and the battery cap are fully extended and not permanently compressed.
- When removing old batteries, check the battery tips for blackening. These oxidation deposits are caused by arcing, and some batteries tend to be worse than others. The arcing is caused by intermittent separation between the batteries and/or contact points.
- Taping the batteries together can reduce arcing potential. If using a 4-cell transmitter, it is recommended that the batteries be soldered together to avoid arcing or compression of contacts.
- If concerned that battery life in the transmitter is shorter than noted in the specifications provided in the Transmitter Section, please refer to the "Current Draw Test" above under "Transmitter Tests."

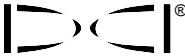

**Notes**

# Locating

## Locating Mode

To locate the transmitter the receiver's trigger must be held in. This is referred to as the "locating mode". When the trigger is held in, the top left window will stop displaying pitch with the flashing pitch/roll update squiggle ("~") and will instead display signal strength and the "+/-" indicator. The plus ("+") and minus ("-") signs in the top left window are the key to locating and will guide the operator to the tool (transmitter) using three locations, not just the peak signal.

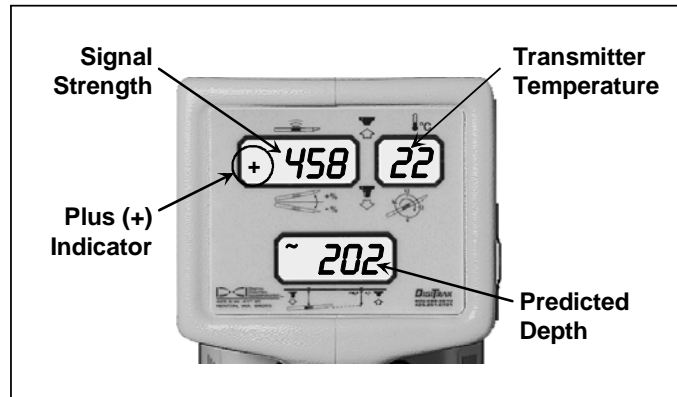

Locating Mode (Trigger Held In)

## Locate Points (FNLP & RNLP) and Locate Line (PLL)

Two of the three locations used for guiding the operator to the tool are points that represent extensions of the transmitter. One point is in front of the transmitter (the front negative locate point or FNLP), and the other is behind the transmitter (the rear negative locate point or RNLP).

The third location is a line that represents the position of the transmitter. This line is perpendicular to the transmitter and is referred to as the positive locate line or PLL.

**Geometry of FNLP, RNLP, and PLL from Top and Side Views**  
 Note how RNLP and FNLP are equal distances from the PLL.

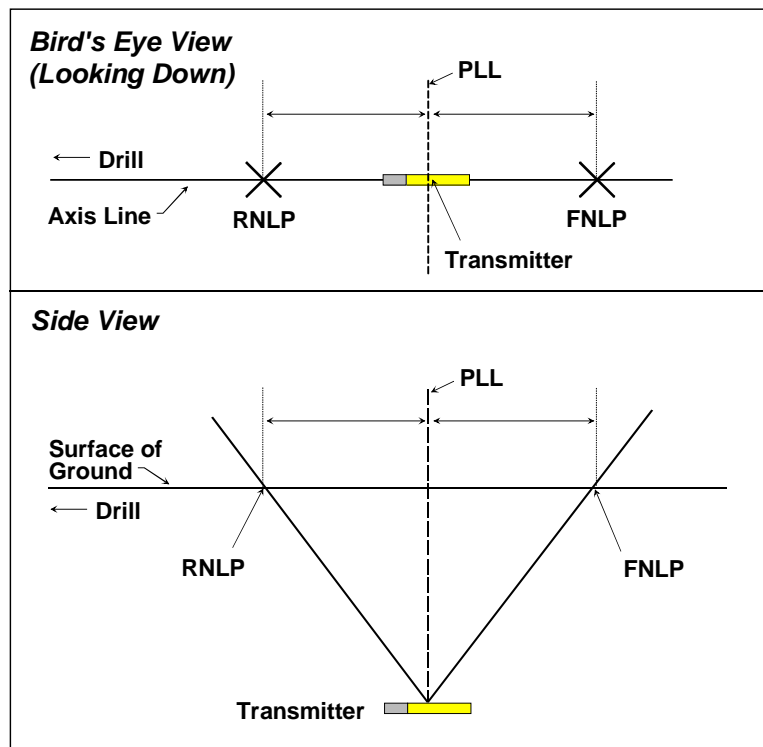

## Handling the Receiver

For the most accurate locating, the receiver must be held level and parallel to the transmitter. The receiver can be held so that it faces in the same direction as the transmitter or in the opposite direction (see sketch).

The front and rear negative locate points are denoted as such because each is at a *point* where the sign changes from *positive* to *negative*. It doesn't matter if the receiver and transmitter are facing in the same direction or in opposite directions, the plus sign will change to a minus sign at either of the locate points. In fact, you can approach the FNLP or RNLP from any direction and the sign will change from plus to minus.

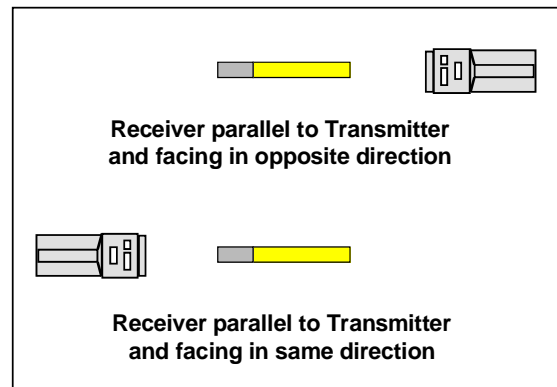

**Receiver Can Face in Either Direction  
with Respect to Transmitter**

The positive locate line (PLL) is not a point (like the FNLP and RNLP). As stated above, the PLL is a line that runs perpendicular to the transmitter and is denoted as such because the negative sign will change to a positive as the receiver crosses the PLL. The position of the transmitter along the PLL can be determined by finding the FNLP. It can also be confirmed by finding the highest signal strength.

## Distance Between FNLP and RNLP Due to Depth, Pitch, and Topography

Because of the transmitter's field shape, the deeper the transmitter, the further apart the FNLP and RNLP will be. The distance between the FNLP and RNLP with respect to the location of the PLL is also a function of the transmitter's pitch and the topography. When the transmitter's pitch is negative, the FNLP will be further from the PLL than the RNLP (see sketch). When the transmitter's pitch is positive, the RNLP will be further from the PLL than the FNLP. If the ground surface or topography slopes significantly, the locations of the FNLP and RNLP will also be affected with respect to the PLL even though the transmitter itself is level. Note that the distance between the FNLP and the RNLP can be used to calculate the depth of the transmitter (see "Calculating the Depth Based on Distance Between FNLP and RNLP" later in this section).

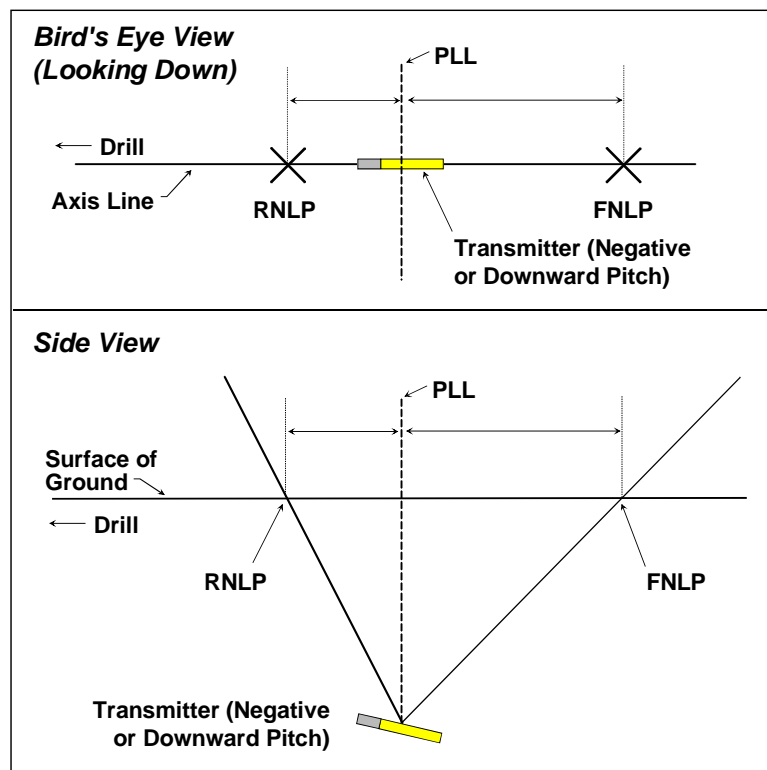

**Effect of Pitch on Distance Between FNLP, RNLP, and PLL**  
Note how the RNLP and FNLP are at different distances from the PLL when the Transmitter is at a negative pitch (compare with sketch on previous page in which Transmitter is level).

In summary, the three locations mentioned above are as follows: the rear negative locate point (RNLP), behind the transmitter; the positive locate line, above the transmitter; and the front negative locate point (FNLP), ahead of the transmitter. The RNLP and the FNLP show the position and lateral orientation of the transmitter.

## Using Plus/Minus Indicators for Locating

The “+” and “-” signs indicate the direction to move the receiver to locate the transmitter. The “+” sign means move the receiver forward, and the “-” sign means move it backward.

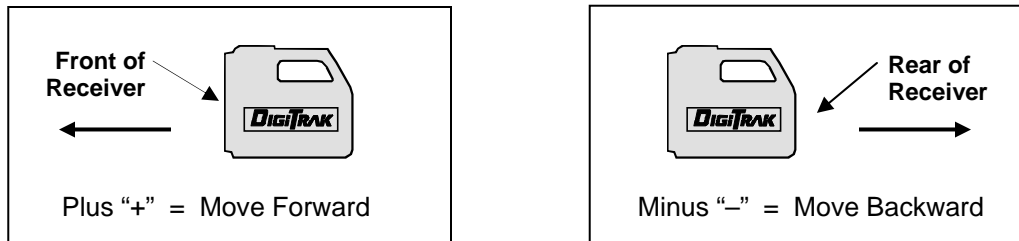

*Using Plus/Minus (“+/-”) Indicators for Locating*

## Locating the Transmitter from the Drill

The procedure for locating the transmitter starting at the drill is given below. A similar procedure can also be used to locate the transmitter from the front, facing toward the drill (see “Locating the Transmitter from the Front” later in this section).

### Finding the Rear Negative Locate Point (RNLP)

1. With the trigger held in, walk toward the transmitter; the signal strength in the top left window will increase. Observe the point at which the “+” sign in the top left window changes to a “-” sign. This is the RNLP. Move the receiver forward and backward a little until the exact location can be identified where the “+/-” signs flip from one to the other. This is the approximate longitudinal (fore/aft) position of the RNLP.

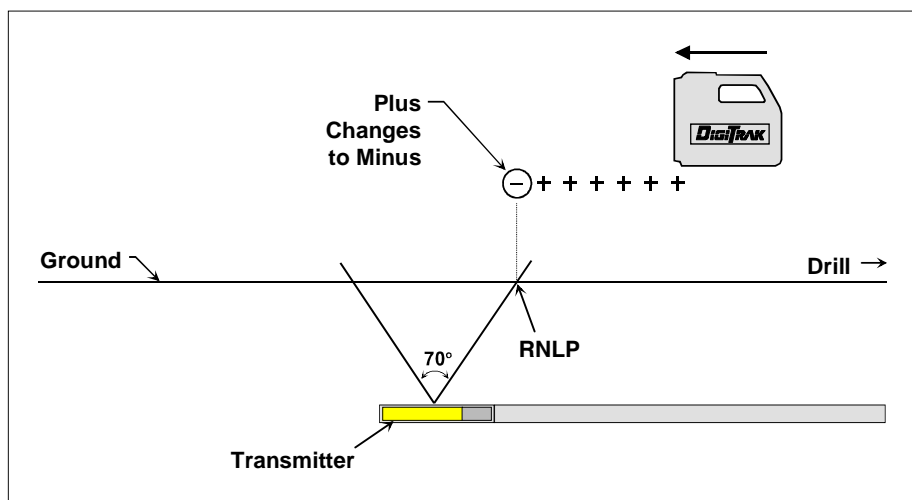

*Finding the Rear Negative Locate Point (RNLP) from the Drill*

- To determine the lateral and therefore the *actual* location of the RNLP, turn toward the left so that the receiver is perpendicular (90°) to the drill string and move the receiver forward. Again, move the receiver slightly forward and backward until pinpointing the location where the “+/-” signs flip from one to the other.

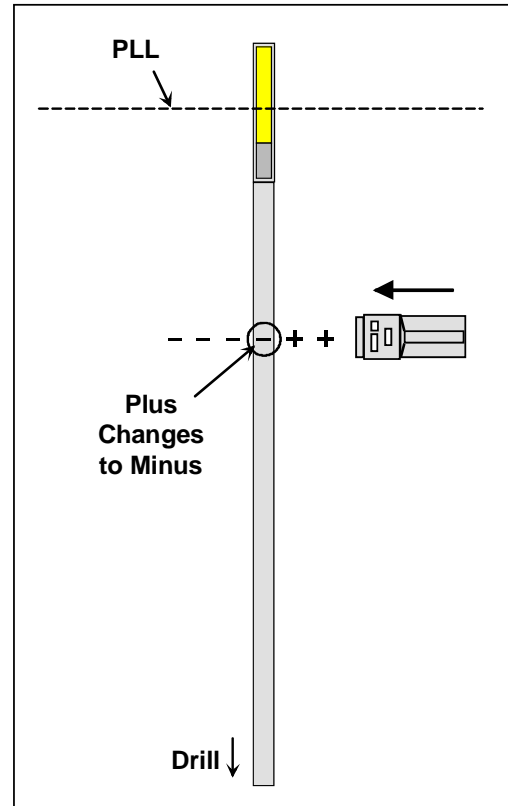

***Fine Tuning the RNLP Location (Walking Toward Left)***

## ***Finding the Positive Locate Line (PLL)***

- At the RNLP, face away from the drill with the trigger held in and walk toward the transmitter. The signal strength should increase. Watch for the “-” sign to change to a “+” sign. Once this occurs, move the receiver slightly forward and backward and find the spot where the “+/-” signs flip from one to the other. This location is the PLL along which the transmitter is located. Mark this spot as a line across the drill string, representing the transmitter’s positive locate line.

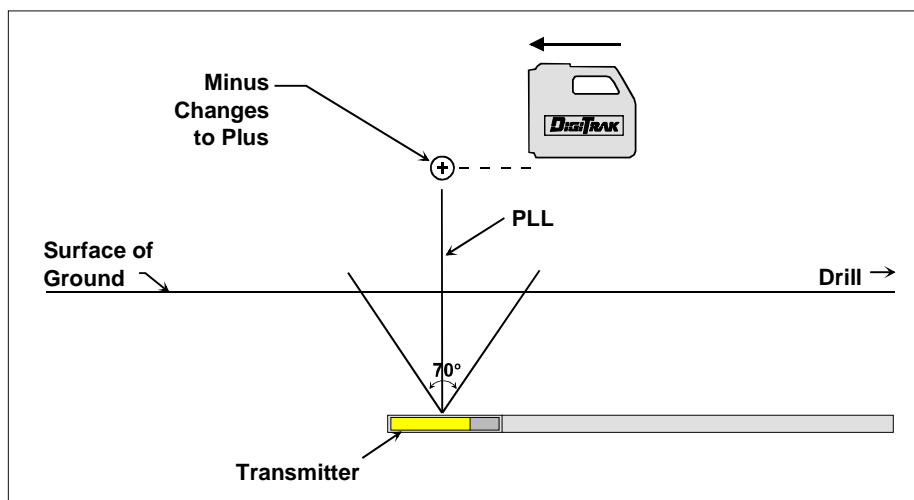

***Finding the Positive Locate Line (PLL) from the Drill***

## Finding the Front Negative Locate Point (FNLP)

- At the PLL, continue walking away from the drill with the trigger held in; the signal strength will decrease. When the “+” sign flips to a “-” sign, this is the FNLP. Again, move the receiver forward and backward a little pinpointing the location where the “+/-” signs flip from one to the other.

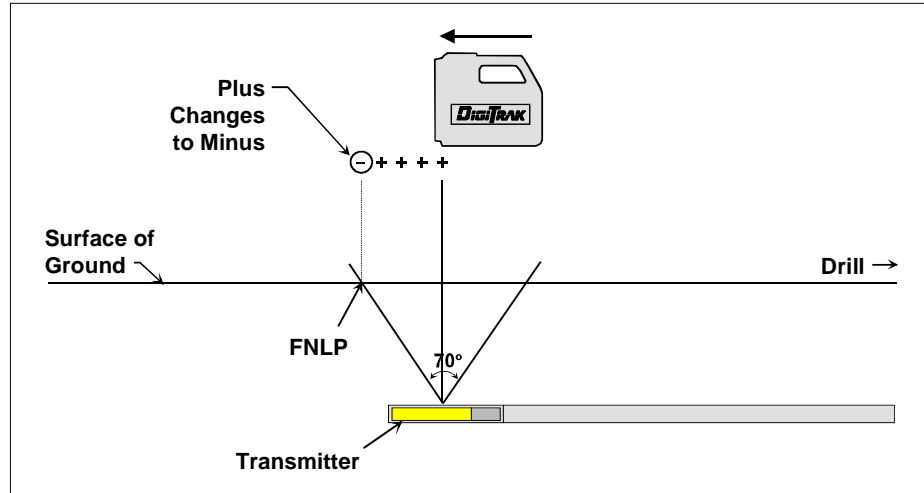

**Finding the Front Negative Locate Point (FNLP) from the Drill**

- To find the *actual* location of the FNLP, turn toward the left so that the receiver is perpendicular (90°) to the drill string and move the receiver toward the *left* side of the drill string and, again, move the receiver forward and backward until pinpointing the location where the “+/-” signs flip from one to the other. Mark this spot.
- When the trigger is held in at the FNLP (and *only* the FNLP) the bottom window displays a prediction of the transmitter’s depth as it would pass under the FNLP, assuming no change in the pitch of the transmitter. To distinguish the predicted depth from the slant distance (trigger released), the bottom window will flash the predicted depth with a solidly illuminated squiggle (“~”). For receivers that have pre-5.0 series firmware, the predicted depth feature is not available. (see “5.0 Series Firmware Functions” in the Receiver Section)

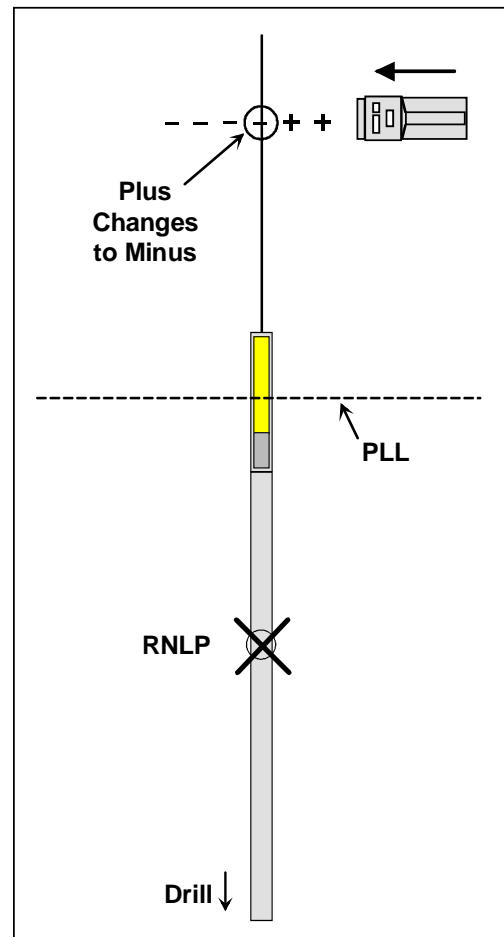

**Fine Tuning  
the FNLP  
(Walking  
Toward Left)**



## Finding the Transmitter and Its Depth

7. While standing on the FNLP facing the drill, it is possible to “sight in” or align the FNLP with the RNLP. This axis line is at a 90° angle (perpendicular) to the PLL. Where this axis line crosses the PLL is where the transmitter will be found, below ground surface.

Take the receiver to the transmitter's location and measure the depth of the transmitter. The receiver must be parallel to the transmitter when it is directly above it to get an accurate depth. It does not matter if the receiver faces the drill or faces away from the drill. The receiver may either be held or set on the ground to find the depth, but be sure the ultrasonics are set correctly (see “Ultrasonic Function” in the Receiver Section). Do not hold in the trigger.

It is usually preferable to maintain separation between the receiver and the ground to minimize underground interference sources. Setting the receiver on the ground is more likely to result in inaccurate depth information in most situations.

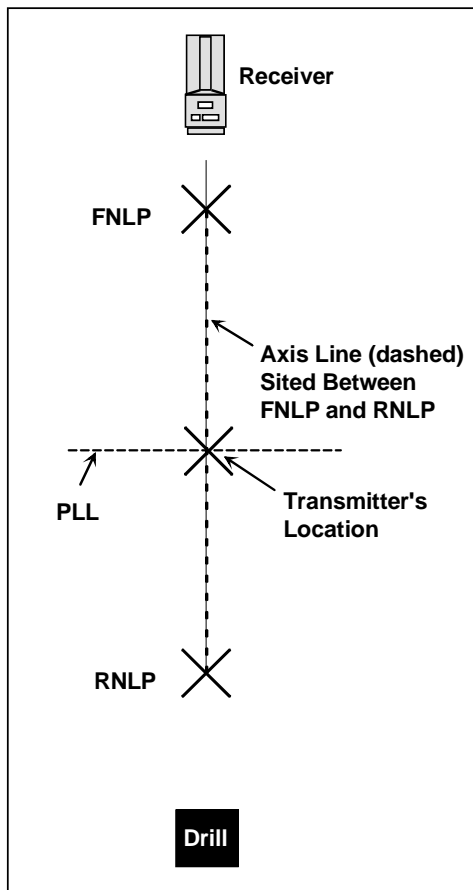

**Finding the Transmitter's Location**

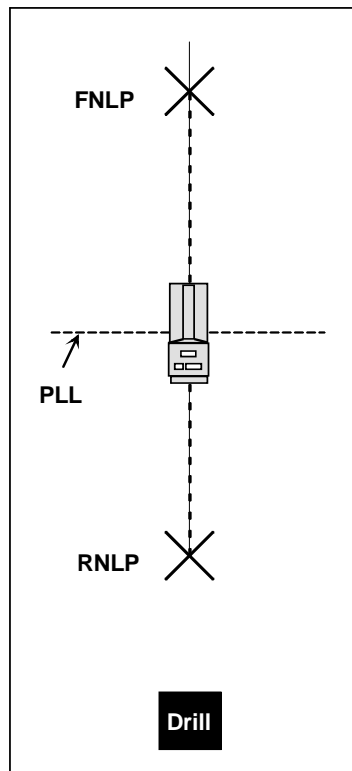

Receiver Facing Toward Drill

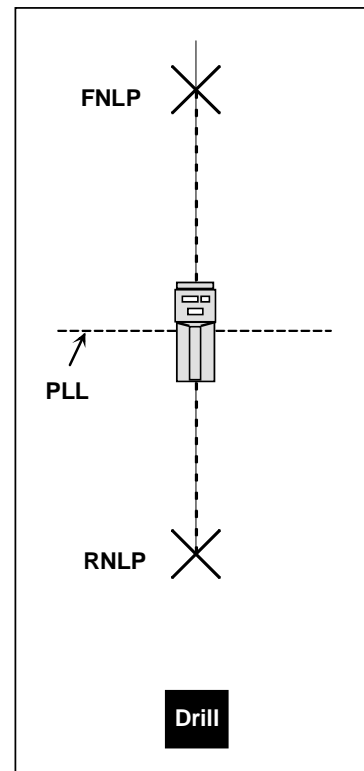

Receiver Facing Away from Drill

**Receiver Position for Measuring Depth of Transmitter**

## Locating the Transmitter from the Front

The transmitter's three locations can be determined in a similar manner as described above starting in front of the transmitter while facing the drill.

Start at a location well ahead of the transmitter and hold in the trigger while facing the drill. A "+" sign should appear in the top left window (along with the signal strength). Walking toward the transmitter, the "+" sign will change to a "-" sign at the FNLP. Continue walking toward the transmitter and the "-" sign will change to a "+" sign at the PLL. Continue walking toward the drill and the "+" sign will change to a "-" sign at the RNLP.

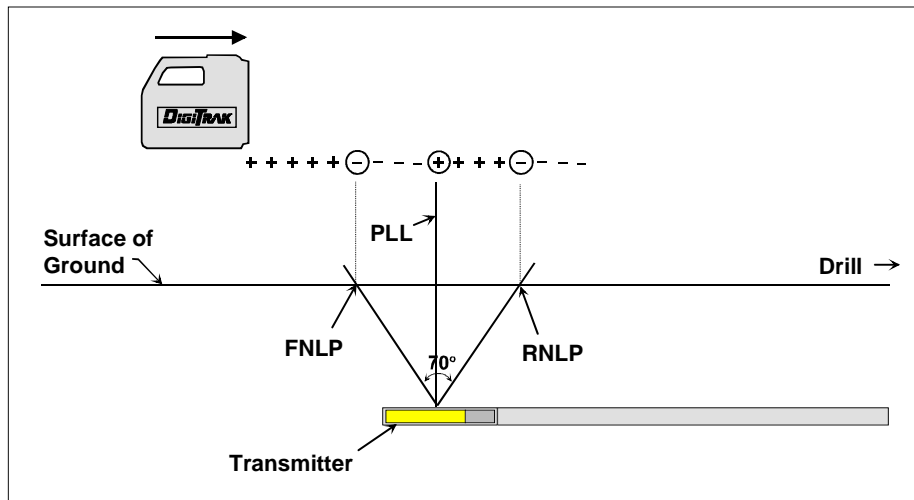

*Locating the Transmitter from the Front*

## Method for Confirming Position

There is a simple method to determine whether the receiver is positioned above the FNLP, RNLP, or transmitter. Rotate the receiver around the "plumb line" axis of the receiver with the trigger held in (see "Using Depth Antenna Plumb Line to Mark Locate Points" in the Receiver Section). If the receiver is above the FNLP or RNLP, the signal strength will remain the same. If it is being rotated above the transmitter, the signal strength will vary by approximately 50%.

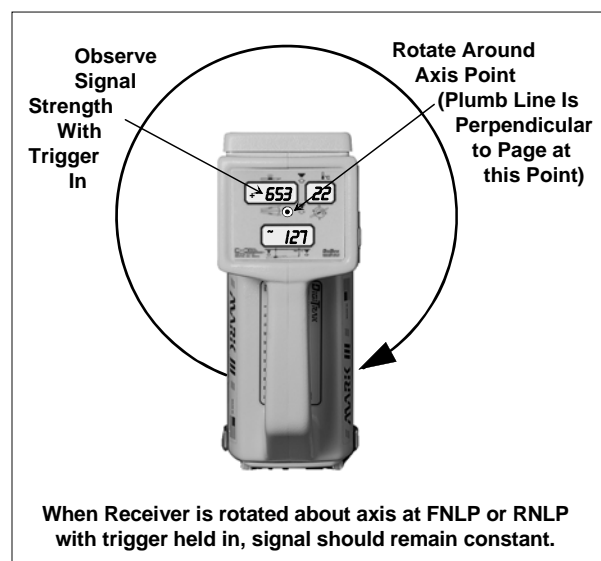

*Method for Confirming Position*

## Locating on the Fly

Once you are comfortable finding the transmitter's three locating points (FNLP, RNLP, and PLL) it is time to increase your speed at locating. Hopefully this will directly affect your productivity!

1. Mark the position of the FNLP and pace out the distance of the next drill rod (this distance will vary depending upon the pitch of the transmitter and the topography).
2. Face the drill and hold the trigger in on the receiver. A "+" sign should appear in the top left window. As the tool advances, the FNLP will approach and the "+" sign will change to a "-" sign as the FNLP passes underneath.
3. Turn the receiver perpendicular to the drill string. Find and mark the FNLP by moving the receiver across the drill string.
4. Turn to face the drill again and with the trigger held in walk toward the transmitter. The "-" sign changes to a "+" sign at the PLL.
5. "Sight in" or align the position of the FNLP with the PLL, and the transmitter will be below this point. (It is possible to verify the transmitter's position by "sweeping" the receiver over the transmitter with the trigger held in looking for the highest signal. However, the signal strength can be affected by interference and should not be relied upon.)

## Off-Track Locating

This technique is useful when an aboveground obstruction or interference prevents a direct walkover. The receiver can still track the PLL when positioned off to the side. The PLL runs through the center of the transmitter at exactly 90° to its axis and extends outward until the transmitter's signal becomes too weak to use. The PLL can be found by stepping off to either side of the transmitter and finding where the "-" sign changes to a "+" sign. The heading of the transmitter can also be confirmed by finding the PLL at three locations off to the side.

1. Determine that the transmitter's pitch matches the ground surface slope. Maintaining a drill pitch parallel to the surface and working on fairly flat ground will ensure the most accurate off-track locating.
2. Walk a predetermined distance sufficient to avoid the obstruction to the side of the borepath and note the slant distance in the bottom window (trigger released).
3. Walk parallel to your intended borepath with the trigger held in; the "-" sign in the top left window will change to a "+" sign at the PLL. Note the slant distance in the bottom window with the trigger released (Point 1).

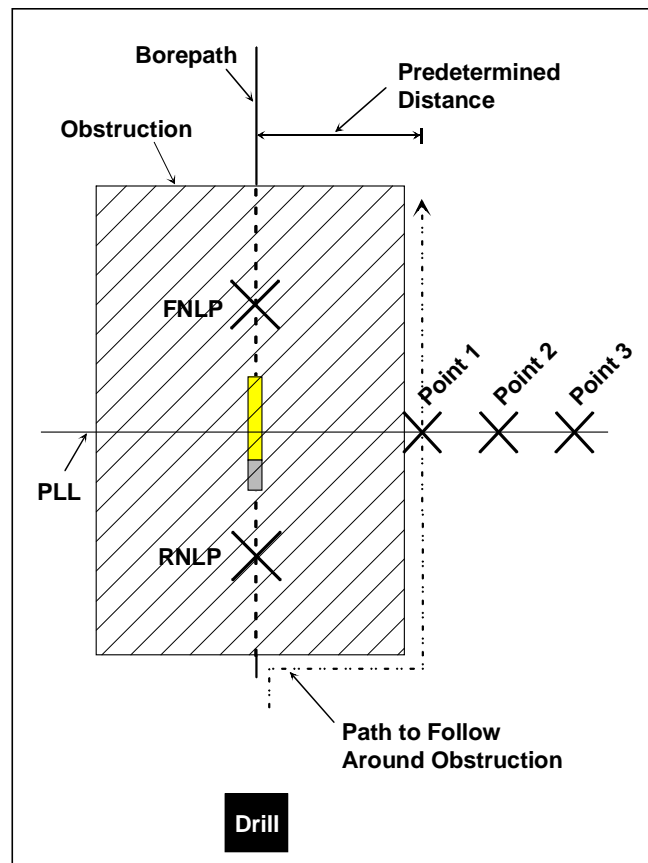

**Off-Track Locating**

4. Step further to the side of the transmitter and again find the point where the “-” sign changes to a “+” (Point 2).
5. Repeat this procedure to find the third location (Point 3).

When all three of these points are lined up, they confirm the location of the PLL, from which the heading of the transmitter can be determined, because the PLL is at a 90° angle to the transmitter. As drilling continues, the drill should be steered to maintain constant slant distances at either of Points 1, 2, or 3. If the slant distance increases, the transmitter is moving away. If the slant distance decreases, the transmitter is moving toward the side position.

## Splitting the Front and Rear Negative Locate Points

At increased depths, a phenomenon occurs whereby the fine tuning of the FNLP and RNLP (when the receiver is held perpendicular) results in a range or distance between the FNLP (or RNLP) which requires you to “split” this range or distance for the true FNLP (or RNLP).

For instance, find the FNLP by walking out in front of the transmitter (your back is towards the drill). Now turn perpendicular so your left shoulder faces the drill. With the trigger held in continue to walk towards the left side of the drill string, note that the “+/-” signs will change back and forth from one to the other. Continue walking until the minus sign “locks in” and mark this location. Turn 180° and walk towards the right side of the drill string with the trigger held in. Continue walking until the minus sign finally “locks in” and mark this location. The true FNLP will be found by “splitting” this distance between the two marked locations you found. Use this same technique for fine tuning the RNLP.

## Four-Turn Technique

The four-turn technique is another method for finding the FNLP or the RNLP. This may be used when a new crew is sent to complete a bore that was started by another crew or to locate a “lost” transmitter. The four-turn technique is so-named because the FNLP or RNLP is found by turning the receiver a maximum of four 90° turns while following the “+/-” indicators.

### To find the FNLP or the RNLP:

1. Be sure the transmitter is awake and the receiver has completed its start-up.
2. Hold in the trigger and rotate the receiver around the plumb line axis point (see the “Using Depth Antenna Plumb Line to Mark Locate Points” in the Receiver Section) until you see a “+” sign in the top left window.
3. Walk in the direction the receiver is facing when the “+” sign is found (keeping the trigger held in) until the “+” sign changes to a “-” sign .
4. Turn the receiver 90° to the left.
5. You will see either a “+” sign or a “-” sign in the top left window (keeping the trigger held in). If you see a “+” sign, walking forward. If you see a “-” sign, rotate the receiver 180° and you should see a “+” sign. Walk in that direction.
6. When the “+” sign changes to a “-” sign, again turn the receiver 90°, looking for the “+” sign. If, after turning the receiver 90° there is a “-” sign, turn 180° to obtain a “+” sign.



7. Repeat steps 2 through 6 until the “+/-” signs flip from one to the other over a very small area. This is either the FNLP or the RNLP. To find the other locate point, walk in the assumed direction of drilling. If the signal strength increases you are at the RNLP; if it decreases you are at the FNLP.
8. To confirm you are over the FNLP or RNLP (as opposed to being over the transmitter), rotate the receiver (with the trigger held in) 360° at the FNLP or RNLP. The signal strength should remain constant during the entire rotation. If the signal strength changes significantly, you are not directly above the FNLP or the RNLP.

## Calculating Depth Based on Distance Between FNLP & RNLP

It is possible to estimate the transmitter’s depth should the information displayed in the depth/distance window become unreliable. This is only possible if the pitch and negative locate points are reliable and the ground surface is level.

To estimate the transmitter’s depth, first measure the distance between the FNLP and the RNLP. The pitch of the transmitter must also be reliably known. Using the Depth Estimation Table below, find the divider that most closely corresponds to the transmitter’s pitch. Then use the following formula to estimate the depth:

$$\text{Depth} = \frac{\text{Distance between FNLP and RNLP}}{\text{Divider}}$$

For example, if the transmitter’s pitch is 34% then the corresponding divider value (from the table) is 1.50. In this example, the distance between the FNLP and the RNLP is 11.5 ft (3.5 m). The depth would be:

$$\text{Depth} = \frac{11.5 \text{ ft}}{1.50} = 7.66 \text{ ft or approximately } 7.7 \text{ ft (2.35 m)}$$

**Depth Estimation Table**

Pitch	Divider	Pitch	Divider	Pitch	Divider	Pitch	Divider
0	1.41	26	1.47	52	1.62	78	1.84
2	1.41	28	1.48	54	1.63	80	1.85
4	1.42	30	1.48	56	1.64	82	1.87
6	1.42	32	1.49	58	1.66	84	1.89
8	1.42	34	1.50	60	1.68	86	1.91
10	1.42	36	1.51	62	1.69	88	1.93
12	1.43	38	1.52	64	1.71	90	1.96
14	1.43	40	1.54	66	1.73	92	1.98
16	1.43	42	1.55	68	1.74	94	2.00
18	1.44	44	1.56	70	1.76	96	2.02
20	1.45	46	1.57	72	1.78	98	2.04
22	1.45	48	1.59	74	1.80	100	2.06
24	1.46	50	1.60	76	1.82		

## Running off Pitch or Calculating Depth from Pitch

The transmitter's depth can be estimated by using the pitch information. Use the following procedure to estimate the depth based on the pitch, starting with the first rod.

1. At the point the drill head penetrates the surface of the ground to the middle of the transmitter's slots (entry point), measure the amount of rod left on the rack (from the make-up/breakout clamps to the top of the rod). This will tell you how much of the first rod with the transmitter will go underground. To calculate the depth after the first rod, use the table below the DigiTrak Receiver handle and choose a pitch reading closest to the entry angle. Multiply the depth number from the table by the ratio of the rod length that went into the ground. For instance, using 10-ft (3-m) rods and measuring 8 ft (2.4 m) left on the rack, the ratio is 8/10 or 0.8. Multiply 0.8 by the depth number from the table. As an example, if the launch angle is 28%, the closest pitch on the label is 30% which corresponds to a depth change of 34 inches (86 cm). Multiply 34 inches (86 cm) by 0.8 to give the calculated depth, which is 27.2 inches (69 cm).
2. For each additional rod, use the table on the receiver to determine how much depth is gained or lost and multiply by the rod length (see table provided in Appendix called "Depth Increase in Inches per 10-foot Rod").
3. For all negative pitch readings, depth is gained or increased.
4. For all positive pitch readings, depth is lost or decreased.
5. If pitch readings fluctuate over the length of the rod, it will be necessary to average the pitch readings for that rod. For instance if the pitch at the beginning of the rod was 8%, halfway it read 6%, and at the end it was 4%, then the average pitch for that rod will be 6%  $[(8 + 6 + 4) \div 3 \text{ readings} = 6]$ . Another example is  $-2, 0,$  and  $2$  as pitch readings at the beginning, halfway, and end (respectively) would average as a 0% pitch over that rod  $[(-2 + 0 + 2) \div 3 \text{ readings} = 0]$ .
6. Note that these estimates are approximate only and accuracy depends on accurate pitch and other measurements.

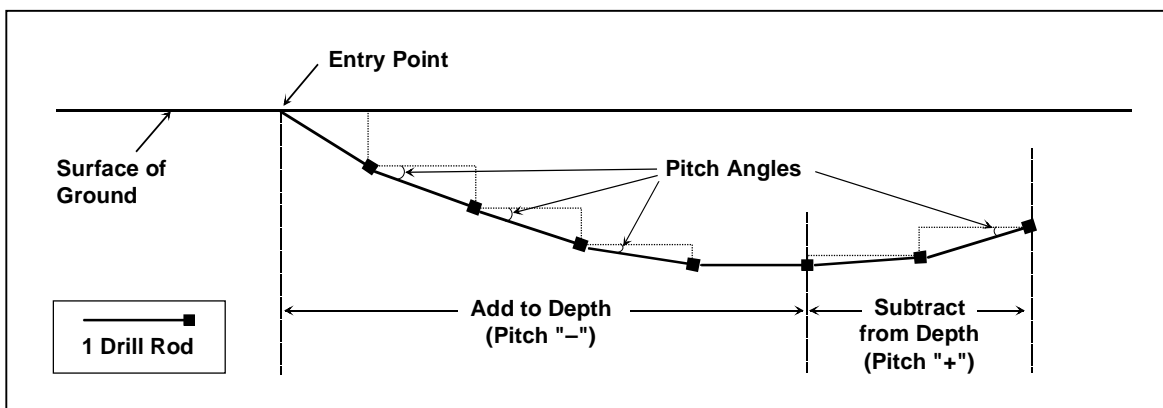

**Calculating Depth from Pitch**

## Transmitter's Signal Shape

It is important to understand some fundamental concepts about the transmitter's electromagnetic signal and the way the receiver's antennas read or receive this signal. The shape of the transmitter's signal field is elliptical. This elliptically shaped field combined with the DigiTrak Receiver's unique "X" antenna configuration results in locating the transmitter at three specific locations, not just the strongest/highest signal.

The transmitter's electromagnetic field is made up of many "field signal lines." As you locate, you are walking in this magnetic field and your receiver's antennas are picking up signal from those field lines.

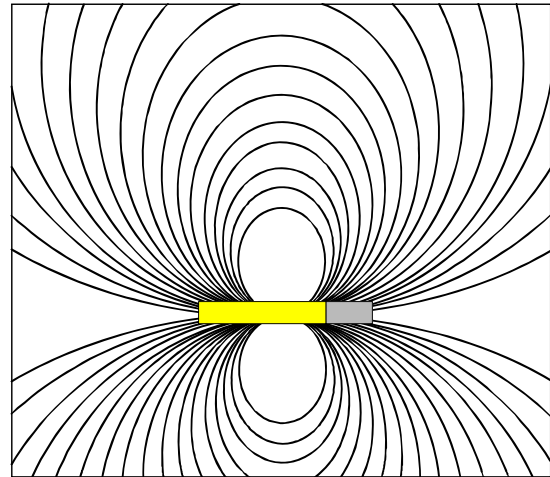

*Elliptical Shape of Transmitter Signal Field*

## Antenna Configuration

The DigiTrak Receiver has a total of three antennas. The single antenna near the bottom of the unit receives pitch, roll, battery, and temperature status from the transmitter. The "locating antennas" are located below the display windows and are in an "X" configuration. One of the antennas is referred to as the minus ("−") antenna and the other as the plus ("+") antenna. The antennas are positioned at right angles to one another (perpendicular), each 45° to the surface below the DigiTrak Receiver. As described above, the more "in-line" the field line is with the antenna, the higher the percentage of "read" signal.

Each antenna receives a different part of the field signal. This information is processed by the receiver to provide the operator with a measurement of the transmitter's entire signal field strength—not just a portion, as with conventional cable locators.

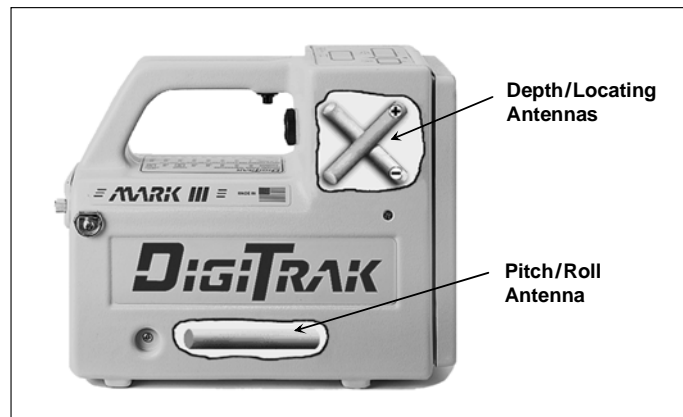

*Location and Orientation of Antennas in Receiver*

## Signal Reception

To understand how the antennas "read" these field lines, it is useful to imagine the field line as a stream of water and the antenna as a pipe. If a stream of water is aligned parallel with the pipe, then 100% of the water will flow through the pipe. If you turn the pipe 90° to the stream of water, no water will enter the pipe. The same principle is true for the field line and the antenna; when they are parallel to one another 100% of the field line will be read by the antenna, and when they are perpendicular to one another none (0%) of the signal will be read.

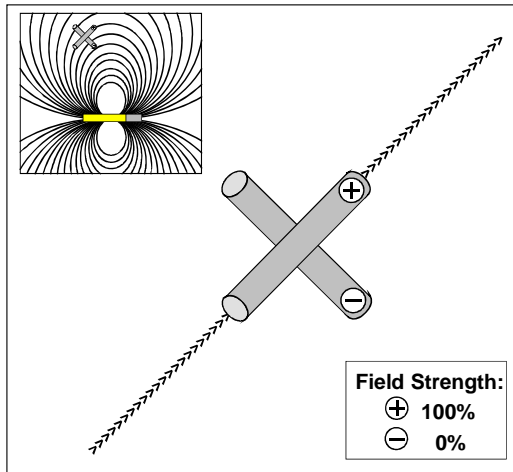

Parallel Field Lines and Antenna

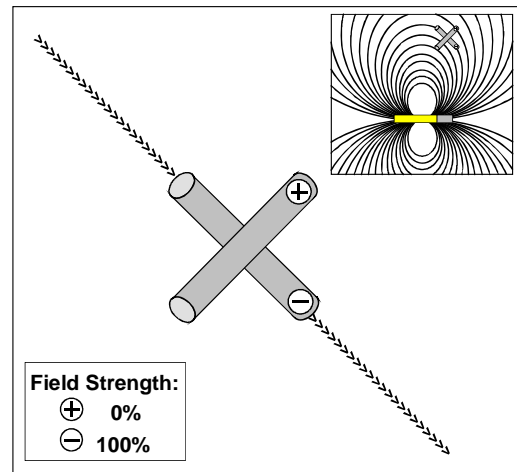

Perpendicular Field Lines and Antenna

### Orientation of Field Lines with Respect to Antennas

## Front and Rear Negative Locate Points

If the field line is vertical with respect to the antennas, each antenna will read 50% of the signal (figure). This occurs at two locations: one behind the transmitter, known as the rear negative locate point (RNLP), and one in front of the transmitter, known as the front negative locate point (FNLP). Each of these locations is a specific point that is independent of the transmitter's signal strength. Both the rear and front negative locate points are important to accurately locating the transmitter, but the FNLP is used more frequently. The FNLP is also used to aid against oversteering.

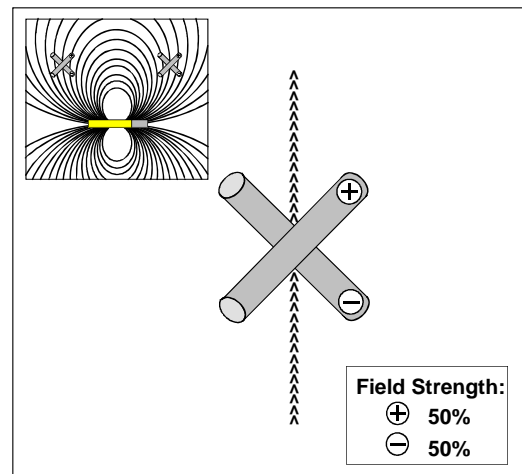

Vertical Field Lines at FNLP and RNLP

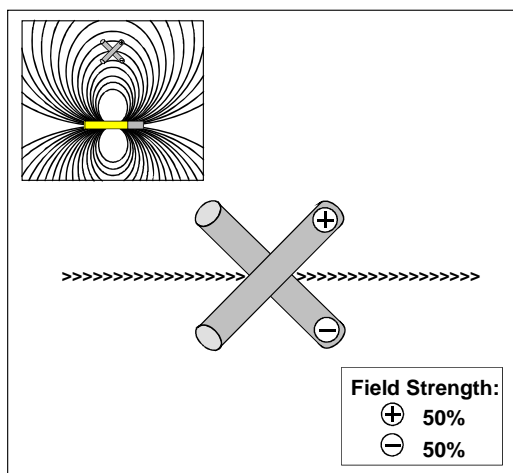

Horizontal Field Lines at PLL

## Positive Locate Line Above Transmitter

When the field line is horizontal with respect to the antennas, each antenna will read 50% of the field strength at that point. This location is directly above the transmitter and is referred to as the positive locate line (PLL). The transmitter's exact lateral location below the PLL can be determined either by using the FNLP and RNLP or by finding the peak signal. However, locating the transmitter's position below ground using the peak signal is not encouraged due to its susceptibility to interference potentials.



## **Notes**

## ***Cable Transmitter System***

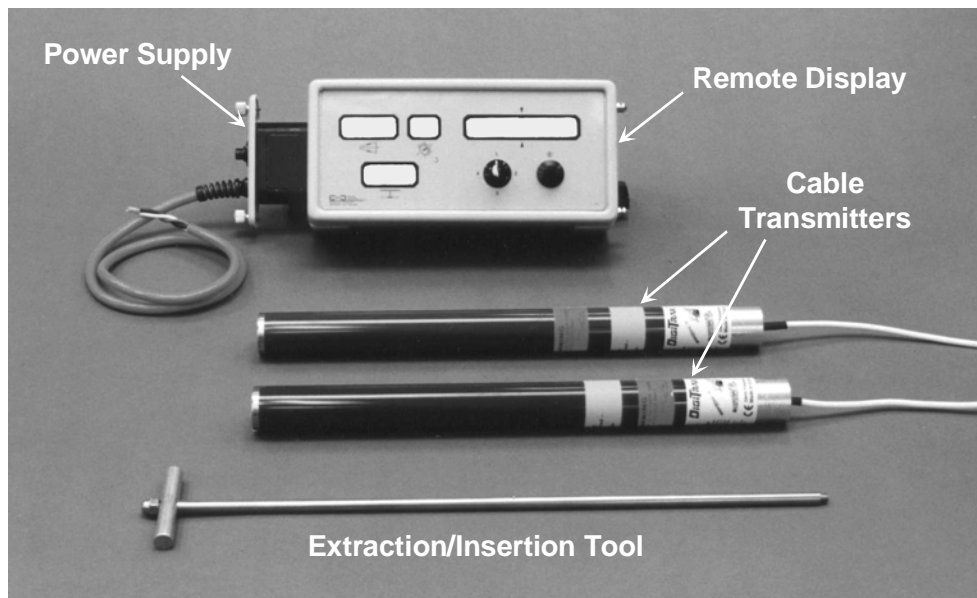

### ***DigiTrak Cable Transmitter System***

The DigiTrak Cable Transmitter System is designed specifically for the following applications:

- Borepaths with depths in excess of 50 ft (15 m).
- Borepaths with lengths that require several days to drill.
- Borepaths that do not allow walkover locating.
- Borepaths in high-interference areas.

The depth and locating range of the cable transmitter with a Mark III Receiver is approximately 140 ft (43 m), and it is approximately 100 ft (30 m) with a Mark I or Mark II Receiver. These depths are also dependent upon environmental conditions and characteristics of the housing. With the Cable Transmitter System it is also possible to obtain pitch and roll information at any depth. Depth and lateral location information is tracked using the DigiTrak Receiver in exactly the same manner as with regular DigiTrak Transmitters. The DigiTrak Receiver operator will not, however, obtain pitch, roll, or temperature information at the receiver because this information is sent directly to the remote display.

The Cable Transmitter System consists of four major components:

**Cable Transmitter** – This transmitter requires a special housing to accommodate the wire. The cable transmitter is inserted into the housing so that the cable extends through the back of the housing awaiting the first butt splice connection. A compression fitting is required to seal the cable transmitter from drilling fluid.

**Remote Display with Cable Transmitter Capability** – This is a remote display that has been upgraded or was originally built to display the cable transmitter data. During operation with a cable transmitter, a delta symbol ( $\Delta$ ) illuminates in the top left window indicating the cable mode. All “cable-ready” remote displays have a label near the battery compartment door that indicates it is configured to receive the cable transmitter’s information (see photo). Not all remote displays have the Cable feature, but all can be upgraded/modified for the cable transmitter function.



***Label Indicating  
Cable-Ready Remote Display***

**Power Supply** – This unit plugs into the remote display where the battery pack normally is inserted and is wired directly to the cable transmitter. The power supply enables the information coming up the wire from the cable transmitter to be displayed on the remote display and it sends power to the cable transmitter from the above-ground batteries. It also contains a circuit breaker to protect the system components.

**Cable Extraction/Insertion Tool** – This tool is used for inserting and extracting the cable transmitter to/from the housing. Two threaded holes (1/4"-20 thread) are provided at the back of the cable transmitter for threading the extraction tool. Never remove the cable transmitter by pulling on the wire.

Items such as compression fittings, 10-gauge stranded copper wire, heat shrink, butt splices, and slip-ring assemblies are not available from DCI. Drill manufacturers will have information on slip-ring assemblies, mud swivels, and compression fittings. Electrical supply houses will carry the rest of the equipment needed for the Cable Transmitter System.

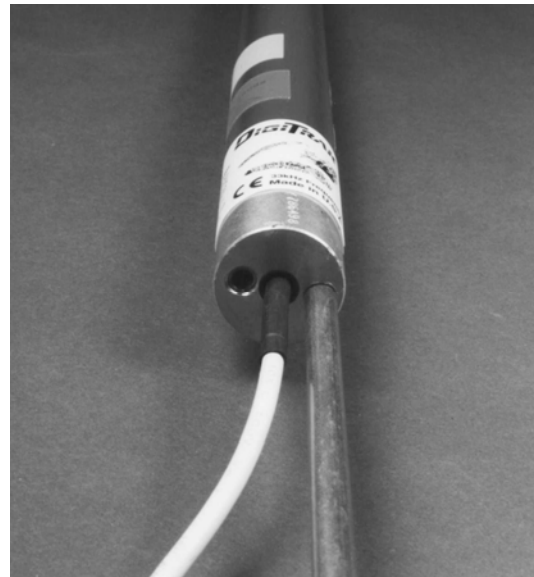

***Cable Transmitter Shown with Cable  
Extraction/Insertion Tool Screwed into End***

## Power Supply

The Cable Transmitter Power Supply plugs into the remote display where a regular DCI battery pack is normally placed. The power supply has three wires extending from it. The green and black wires should be connected to a DC power source (green is positive, black is negative). The white wire is connected to the cable transmitter (see sketch later in this section called “Connecting Cable Transmitter to Power Supply and Remote Display”).

The power supply has the following features:

- There is an on/off button on the power supply that will disconnect power to the cable transmitter. Power should be disconnected any time connections are made or broken. The red indicator light will illuminate when power is supplied. To power up the Cable Transmitter System, it is necessary to turn on both the remote display and the power supply.

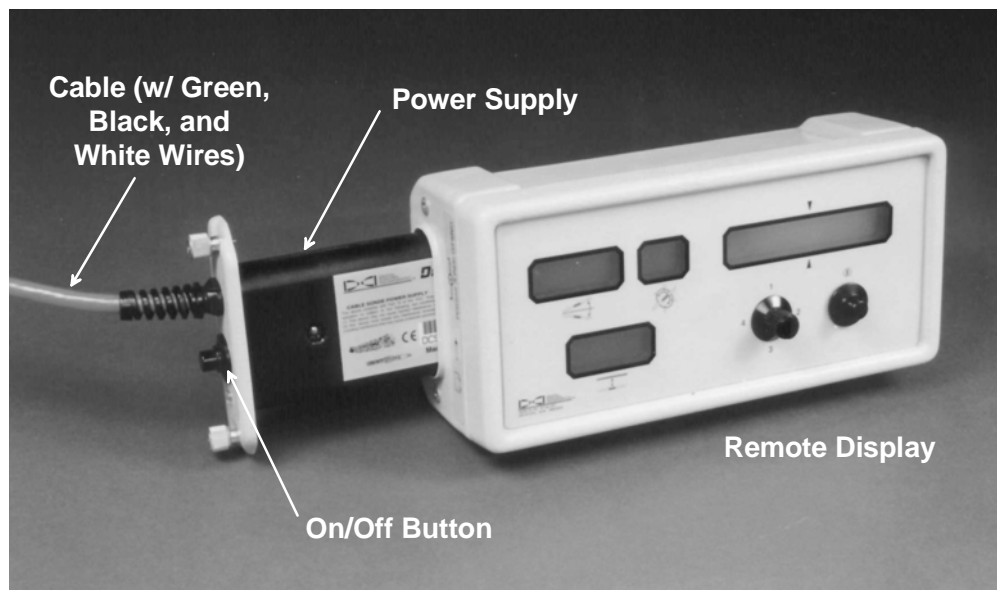

***Cable Transmitter Power Supply Connected to Remote Display***

- The power supply controls and limits the power to the cable transmitter. In the event of a short circuit, power will be disconnected from the transmitter automatically. The power supply indicator light will go out, and the transmitter will shut down. This condition can be corrected by eliminating the short circuit. If the fault condition has been corrected, the power light will come back on automatically and power will be restored to the transmitter.
- The power supply requires an input voltage of 12V to 28V DC.
- The power supply must be turned off at the end of the day to avoid overheating the cable transmitter.

**NOTE:** Do not use the drill's power system as a source of power for the remote display and power supply. Run separate battery(ies) directly to the power supply, not through the auxiliary system on the drill. The Cable Transmitter System can pick up electrical interference and noise introduced through the drill's power system.

## Cable Transmitter

The cable transmitter has the same general features and capabilities as the other DigiTrak Transmitters but with increased depth range. The dimensions of the cable transmitter are the same as those of the 2-cell DigiTrak Transmitters (DT, DX, and DXP). However, there is also a power/signal cable extending from the rear metal grounding cap. The metal grounding cap must make solid contact with the interior of the housing, which is grounded through the drill. The function of the wire is to provide power to the transmitter and to send the pitch, roll, voltage, and temperature information to the remote display.

The cable transmitter is inserted into the transmitter housing, using the cable extraction/insertion tool, so that the cable extends through the back of the housing. A compression fitting is used to seal the transmitter compartment from drilling fluid/water. Optimal compression fitting characteristics include a washer in the uphole side of the rubber stopper (inside compression fitting) and/or a tapered-interior-diameter shaft to avoid stopper inverting due to drilling fluid pressure. The cable is routed through the interior of the drill pipe; it exits the drill pipe at the drive chuck with another compression fitting or through the mud swivel. As drill rods are added, the wires are connected using butt splices plus heat shrink with hot melt glue. A slip-ring or mud-swivel assembly can be used to enable constant monitoring of the transmitter information. These are not required; however, if one is not used, it will be necessary to disconnect while drilling and reconnect the wires in order to view the transmitter information.

The Cable Transmitter System has the following characteristics:

- The calibration procedure is a 1-point calibration; 2-point is required if the cable transmitter is in the ground.
- An input voltage between 12V and 28V DC.
- The typical power source is one or two 12V DC lead-acid automotive batteries, which may be connected in series for 24V DC. With this 24V DC source, approximately 2000 ft (610 m) can be drilled before recharge.

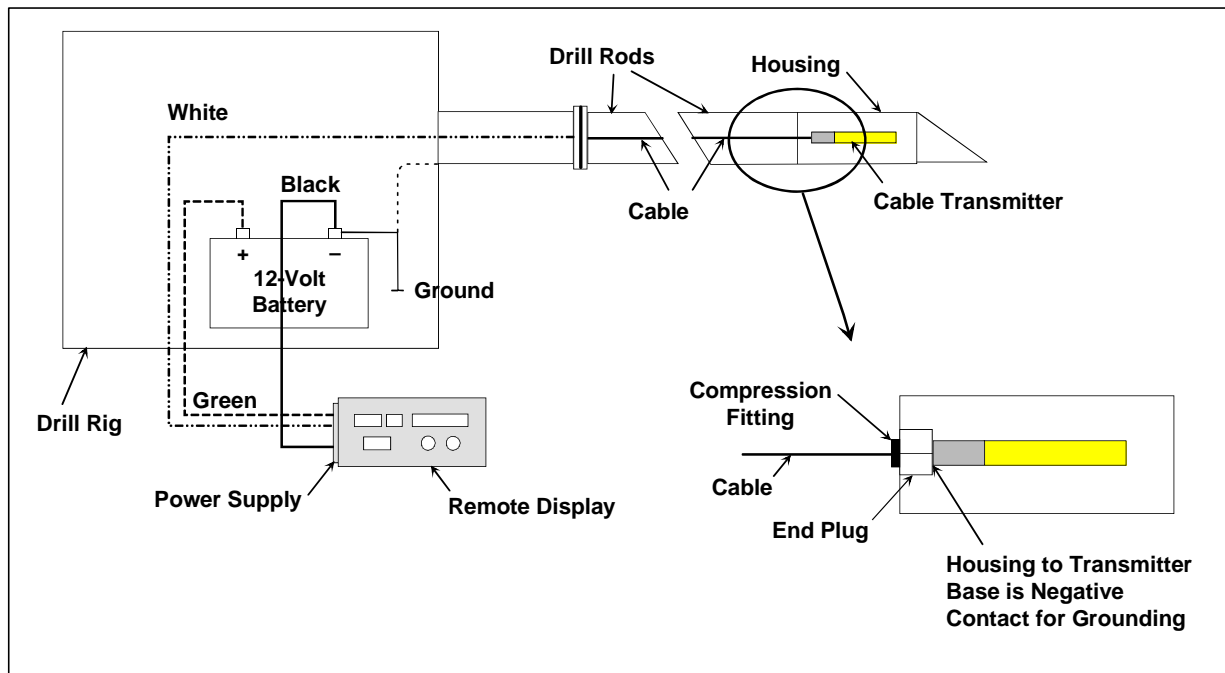

**Connecting Cable Transmitter to Power Supply and Remote Display**

- Temperature information can be accessed manually by turning off and then on the cable-ready remote display.
- Upon supplying power, the cable transmitter will begin transmitting data.
- There is no sleep mode; therefore, the power supply must be turned off manually at the end of the day. Failure to turn off the power overnight can result in an overheated cable transmitter.
- A low battery indication (BAT) could signify that another battery is needed.
- The remote steering feature may be used.
- The DataLog Mapping System may be used.
- An extraction/insertion tool is provided to remove and install the cable transmitter in the housing. The cable transmitter's wire must never be used to remove the transmitter.
- 10-gauge stranded copper wire is suggested for use with the cable transmitter, as are butt splices with hot melt glue heat shrink.
- A compression fitting is necessary behind the cable transmitter to seal drilling fluid from the transmitter cavity.

## Remote Display with Cable Transmitter Capability

The remote display used with the Cable Transmitter System has special components to accept pitch, roll, voltage, and temperature information directly off the wire from a cable transmitter. (When tracking a standard transmitter, the receiver sends the pitch, roll, battery status, and temperature information to the remote display using telemetry.)

The depth and left/right steering information, which is processed by the receiver, is sent to the remote display by telemetry. Therefore, the information on the remote display is a combination of information received from the cable transmitter and from the receiver. The receiver must be set to the same channel as the remote display.

A delta symbol or triangle in the top left window of the remote display indicates if it is operating in the cable transmitter mode. Temperature will be displayed in the top right window of the remote display following a 4°C increase. To view the cable transmitter's temperature at any time, simply turn the remote display unit off and then on (do not turn off the power supply). The temperature will display in degrees Celsius in the top right window for 2 seconds during start-up. (See "Temperature Overheat Warning" in the Transmitter Section.)

The battery indicator (BAT) in the top left window, which is normally used to signal a low battery condition in the transmitter, will now indicate the voltage of the transmitter's above-ground battery(ies). When the BAT symbol appears, it is time to add another battery to the power system. Be sure batteries are added correctly in series (see diagram).

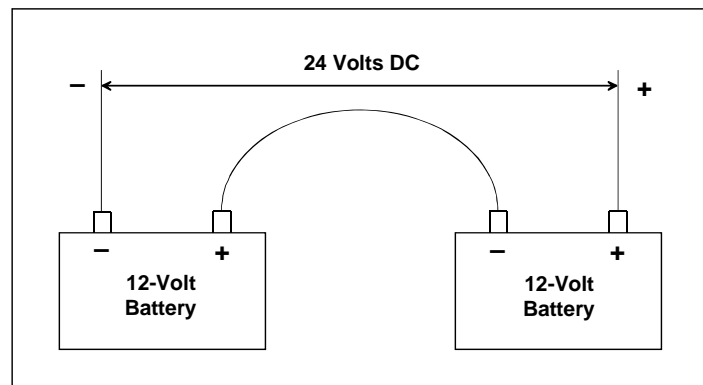

**Adding Batteries in Series**

## Viewing the Cable System Battery Status

The percentage of required voltage will be displayed in the top left window of the remote display for 2 seconds when the transmitter's temperature increases by 4°C, which will be displayed in the top right window. To manually access the voltage status, turn the remote display off and on and observe the top left window after the firmware version is displayed. The voltage status is displayed in percent remaining (above the minimal necessary voltage) and is based on a 28V DC power source. Therefore, 28V will display as 100%, 19V as 50%, 12V as 25%, 9V as 0%.

When a standard DCI battery pack is installed into the remote display, rather than the Cable Transmitter Power Supply, it will automatically switch from the cable transmitter mode. Pitch, roll, temperature, and battery status will again be received by telemetry from the DigiTrak Receiver.

## Operation

The cable transmitter is located using the FNLP, RNLP, and PLL in the same manner as other DigiTrak Transmitters, except the receiver will not display the transmitter's pitch, roll, and battery or temperature status—this information is displayed only on the remote display. Many cable bores do not allow walkover locating; therefore, the depth of the transmitter is often calculated using the pitch information (see “Running off Pitch or Calculating Depth from Pitch” in the Locating Section) or by using the real-time DataLog System.

With the cable transmitter inside the housing/tool and grounded to the drill, complete a 1-point calibration procedure. Ensure that there are no metal objects between the tool and the receiver during calibration. Check depth readings against a measuring tape at varying distances from the cable transmitter. Calibration can be done with the housing tool installed on the drill rig. The pitch angle does not affect calibration.

Note that, because the cable transmitter emits twice the signal strength of a long-range transmitter (DX, DXP, D4X, D4XP), the receiver will be saturated with signal at distances closer than 60 inches (152 cm). Therefore, it may not be possible to obtain a depth reading at distances less than 60 inches (152 cm). To determine the maximum depth range of the cable transmitter, move the receiver away from the transmitter until the depth becomes very unsteady or reads “1999”. Although the depth of the tool can be calculated from the pitch information, it will not be possible to locate the tool by walking over it at depths greater than the maximum range. The ability to locate the FNLP and RNLP is also dependent on the maximum depth range.

Ensure that the remote display and power supply are connected directly to the power source, not through the drill's DC power supply.

A multimeter should be available for power testing/troubleshooting. For detailed instructions on troubleshooting the Cable Transmitter System, please contact Customer Service at 425-251-0559 or 800-288-3610.

## ***Troubleshooting***

<b>Problem/Concern</b>	<b>Causes/Solutions</b>	<b>Section to Consult</b>
1999 in bottom window of receiver, indicating no signal is being received from the transmitter.	Transmitter is asleep (wake it up by rotating the drill string). Dead batteries in the transmitter. Broken transmitter. Overheated transmitter. Transmitter is out of range of receiver.	“Electrical Interference/ Background Noise Check” in Signal Interference Section Transmitter Section
A number ranging from 200 to 700 in bottom window of receiver and transmitter is not active.	Receiver is receiving background noise.	“Electrical Interference/ Background Noise Check” in Signal Interference Section
Depth suddenly decreases 18–24 inches (46–61 cm).	Ultrasonics have not been zeroed and receiver is being set on the ground for depth reading. Due to the likelihood of interference, do not measure with the receiver on the ground.	“Ultrasonic Function” in Receiver Section
Depth after calibration displays as 297–305 instead of 119–121.	Depth measurement mode in receiver has been inadvertently changed from inches (English) to centimeters (metric).	“Changing the Depth Measurement Units” in Receiver Section
Incorrect depth.	Interference. Ultrasonics improperly set. Bad calibration. Weak signal from the transmitter. Receiver is not directly over transmitter when taking a depth reading (trigger must be released). Receiver malfunction.	“Electrical Interference/ Background Noise Check” in Signal Interference Section “Ultrasonic Function” in Receiver Section
Erratic information on receiver.	Interference. Low battery in receiver. Moisture inside the equipment. Call DCI for information about field methods for “drying” out the equipment. Moisture can be caused by condensation which occurs when the equipment is repetitively moved to and from a warm environment and a cold one.	“Electrical Interference/ Background Noise Check” in Signal Interference Section Remote Display Section
Remote display has dashes across windows.	Receiver is set on channel 0 (the telemetry is off). Receiver is set to a different channel than remote display.	“Changing the Receiver’s Channel Setting” in Receiver Section



Problem/Concern	Causes/Solutions	Section to Consult
<p>Remote display has dashes across windows. (Continued)</p>	<p>Interference is interrupting the signal from the receiver.</p> <p>Line of sight between receiver and remote display may be obstructed (by such things as buildings, hills, or dense vegetation).</p> <p>Receiver is not equipped to send a signal back to a remote display. To confirm that your receiver is “remote capable” observe the back of the receiver. There must be a large orange arrow for your receiver to be able to send a signal to the remote display at the drill.</p> <p>Telemetry of receiver is not compatible with telemetry of remote display. Compare the telemetry information located below the serial number on the receiver and the remote display; verify that they match.</p> <p>If possible, substitute another receiver or remote display to determine which piece of equipment is problematic.</p>	<p>“Electrical Interference/ Background Noise Check” in Signal Interference Section</p> <p>Remote Display Section</p>
<p>No pitch, roll, battery and temperature information.</p>	<p>Interference.</p> <p>Receiver may be out of range of transmitter. If possible try another receiver for comparison or a transmitter with a stronger signal strength.</p> <p>Receiver malfunction. If receiver is a Mark III model, complete the self-test.</p>	<p>“Electrical Interference/ Background Noise Check” in Signal Interference Section</p> <p>“Self-Test for Mark III Receivers” in Operational Tests Section</p>
<p>Rolling clock.</p>	<p>Interference.</p> <p>Verify squiggle (“~”) in top left window flashes at regular intervals. If not, signal distortion is present. Try another transmitter to confirm problem.</p>	<p>“Electrical Interference/ Background Noise Check” in Signal Interference Section</p>
<p>Can’t get the “+/-” signs to give a “crisp” flip when attempting to find the FNLP or RNLP.</p>	<p>Interference.</p> <p>Receiver is not being held level and steady.</p> <p>As the transmitter’s depth increases, the locate points may be found on both the left side and the right side of the drill string. When this occurs the distance between these two points is split to find the true FNLP or RNLP.</p>	<p>“Electrical Interference/ Background Noise Check” in Signal Interference Section</p> <p>Receiver Section</p> <p>“Splitting of the Front and Rear Negative Locate Points” in Locating Section</p>

Problem/Concern	Causes/Solutions	Section to Consult
Erratic depth.	<p>Interference.</p> <p>Transmitter is off.</p> <p>If possible, try another receiver or transmitter to identify the problem. The approximate depth may be calculated using the pitch information and the distance between the FNLP and RNLP.</p> <p>Receiver or transmitter malfunction.</p>	<p>“Electrical Interference/ Background Noise Check” in Signal Interference Section</p> <p>“Running Off Pitch or Calculating Depth from Pitch” in Locating Section</p> <p>“Calculating Depth Based on Distance Between FNLP &amp; RNLP” in Locating Section</p>
Transmitter exits further to the left or right than receiver indicated.	<p>Receiver was not held level when locating transmitter.</p> <p>Transmitter is being located by sweeping receiver over it, looking for peak signal instead of using the FNLP and RNLP.</p> <p>Receiver’s antennas are out of balance. The antennas can be balanced by performing a diagnostic procedure over the phone with DCI customer service personnel or by sending your receiver to DCI for testing/repair.</p>	<p>Read Locating Section, which describes the DigiTrak method for finding the transmitter using the FNLP and RNLP. The DigiTrak provides better accuracy using the locate points.</p>
All windows are blank.	<p>Receiver has shut off to conserve battery life. This occurs when the receiver has not received a signal for 15 minutes. Simply click the button to turn the receiver on (all calibration data will be preserved).</p> <p>Receiver will automatically shut itself off if the calibration procedure is attempted before the receiver has completed its start-up process.</p> <p>If the receiver will not stay on, the battery may be dead. Test the battery to see if it is fully charged.</p>	<p>“1-Point Calibration Procedure” in Receiver Section</p> <p>Battery Charger Section</p>
No squiggle (“~”) in top left window.	<p>Interference.</p> <p>Receiver is out of range of transmitter.</p> <p>Transmitter or receiver malfunction. If possible substitute a different receiver or transmitter.</p>	<p>“Electrical Interference/ Background Noise Check” in Signal Interference Section</p>
100 or -100 in top left window (with trigger released).	<p>Pitch sensor in transmitter has malfunctioned. Replace transmitter.</p>	<p>Transmitter Section</p>
99 in top right window (with trigger released).	<p>Transmitter temperature sensor has malfunctioned. Replace transmitter.</p>	<p>Transmitter Section</p>

Problem/Concern	Causes/Solutions	Section to Consult
Minus sign (“-”) in bottom window.	<p>Receiver is set on ground for depth reading, particularly at shallow depths, and the ultrasonics are not reset. Reset the ultrasonics.</p> <p>Receiver has gone out of calibration. Recalibrate using either 1-point or 2-point calibration.</p>	<p>“Ultrasonic Function” in Receiver Section</p> <p>“Calibrating the Receiver” in Receiver Section</p>
Roll positions sticking or not accurate.	<p>Interference (squiggle in top left window will not blink regularly).</p> <p>If squiggle is blinking regularly, there may be a transmitter or receiver malfunction. If possible substitute a different receiver.</p> <p>If you have a Mark III Receiver, conduct a self-test for error code and failure determination.</p> <p>Transmitter has been overheated (temp dot is black).</p>	<p>“Electrical Interference/ Background Noise Check” in Signal Interference Section</p> <p>“Self-Test for Mark III Receivers” in Operational Tests Section</p> <p>“Temperature Overheat” in Transmitter Section</p>
Not getting a solid depth reading.	<p>Interference.</p> <p>The approximate depth may be calculated using the pitch information along with the distance between the FNLP and RNLP.</p>	<p>“Electrical Interference/ Background Noise Check” in Signal Interference Section</p> <p>“Running Off Pitch or Calculating Depth from Pitch” in Locating Section</p> <p>“Calculating Depth Based on Distance Between FNLP &amp; RNLP” in Locating Section</p>
Bottom window depth/ distance flashes (with trigger released).	<p>Transmitter is being exposed to temperatures in excess of 60°C (140°F). Verify that temp dot is not black before further use of transmitter.</p>	<p>Transmitter Section</p>
Flashing squiggle (“~”) in bottom window.	<p>Transmitter has been exposed to temperatures in excess of 60°C (140°F). Verify that temp dot is not black before further use of transmitter.</p>	<p>Transmitter Section</p>
Solid squiggle (“~”) in bottom window.	<p>With 5.0 and later series firmware, the receiver will display the transmitter’s predicted depth at the FNLP in the bottom window, along with a solidly illuminated squiggle, when the trigger is held in. Pre-5.0 series firmware will not do this.</p>	<p>“5.0 Series Firmware Functions” in Receiver Section</p> <p>Locating Section</p>

Problem/Concern	Causes/Solutions	Section to Consult
<p>Ultrasonics don't work.</p>	<p>Check ultrasonic holes on bottom of receiver for mud or debris. If dirty, carefully clean them out. Be extremely careful not to puncture the metal inside the ultrasonic holes. Use isopropyl alcohol (99% by volume) in modest amounts; swish around (upside down) and fling out the liquid. Repeat two more times and allow to dry for about 15 minutes.</p> <p>If you still cannot get the ultrasonic function to perform properly, call DCI customer service at 425-251-0559 or 800-288-3610 for assistance.</p>	<p>"Ultrasonic Function" in Receiver Section</p>

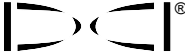

**Notes**

3-3000-001-F

# Glossary

## **Active Transmitter**

A transmitter that has batteries installed or a cable transmitter that is hooked up to power.

## **Battery Charger**

Used to charge and condition (discharge) the DigiTrak batteries. May be used with AC or DC sources and is easily adapted for worldwide usage.

## **Cable Transmitter**

Transmitter that is hard wired directly to the remote display unit and allows information to be obtained during very long and/or deep drilling runs.

## **Clicking vs. Holding Trigger**

See Trigger Clicked, Trigger In, and Trigger Out.

## **DataLog System**

The logging function hardware and firmware used for collecting the data about the drilling operation to produce plots of the borepath location.

## **Depth vs. Slant Distance vs. Range**

**Depth** is the number displayed in the bottom window when the receiver is positioned directly above the transmitter (with the trigger released). **Slant distance** is the number in the bottom window when the receiver is not positioned above the transmitter (with the trigger released). **Range** is the maximum depth of a transmitter; it can be affected by interference from both above- and below-ground sources, conductive soil, and salt water.

## **Drill Head or Tool**

See Housing.

## **English Mode**

The term used to describe depth measurements in inches.

## **Firmware**

The software and hardware configuration programmed in the equipment as provided by the manufacturer. The firmware is not accessible to the user and can only be upgraded by the manufacturer.

## **Four Turn Technique**

An alternative method for finding the FNLP or the RNLP using the plus/minus (“+/-”) indicators. Usually performed when the transmitter’s position is unknown. See “Four Turn Technique” in the Locating Section.

## **Front Negative Locate Point (FNLP) = Locate Point in Front of Transmitter**

This location, used in conjunction with the positive locate line (above the transmitter) and the rear negative locate point, provides the transmitter’s location information to the operator. For more information see the Locating Section.

## **Height-Above-Ground Distance = Ultrasonic Distance = Ultrasonic Measurement**

The height-above-ground or ultrasonic distance is used by the receiver to calculate the depth/distance of the transmitter. For more information see “Ultrasonic Function” in the Receiver Section.

**Housing = Drill Tool = Drill Head**

The downhole device into which the transmitter fits.

**Locate Line and Points**

See Positive Locate Line, Front Negative Locate Point, and Rear Negative Locate Point.

**Magnetic Distance**

The magnetic distance is used by the receiver to calculate the depth/distance of the transmitter. For more information see "Ultrasonic Function" in the Receiver Section.

**Mark III**

Designation used to delineate DigiTrak Receivers with an improved design over the Mark I and Mark II Receivers. The Mark III has special shielding that increases the range of any DigiTrak Transmitter and helps decrease the effects of some types of interference.

**Mark III Self-Test**

Procedure for completing a self-diagnostic test on all the components of the receiver except the ultrasonic transducers (other ultrasonic components are tested). The self-test must be completed in an interference-free area and out of range of any active transmitters. For more information see "Self-Test for Mark III Receivers" in the Operational Tests Section.

**Metric Mode**

The term used to describe depth measurements in centimeters.

**Pitch**

The angle or inclination of the transmitter relative to the horizontal displayed in percent (%) slope (rise divided by run). DCI transmitters can measure and display pitch in both 1% and 0.1% increments.

**Positive Locate Line (PLL) = Line Above Transmitter that Runs Perpendicular to the Transmitter**

This location in conjunction with the FNLP and/or RNLP determines the position of the transmitter below ground.

**Predicted Depth**

The predicted depth provides a prediction of the transmitter's depth at the FNLP when the operator holds in the receiver's trigger. The predicted depth is displayed in the bottom window as a flashing number and a solidly lit squiggle ("~") symbol. For more information see "5.0 Series Firmware Functions" in the Receiver Section and see the Locating Section.

**Rear Negative Locate Point (RNLP) = Locate Point Behind Transmitter**

This location is used in conjunction with the positive locate line and the FNLP to provide the transmitter's lateral location and direction of movement. For more information see the Locating Section.

**Receiver**

Also referred to in the HDD industry as a locator, it is the portable device that is used above ground to receive the transmitter's signals, process the signal information, and display the transmitter's status to the operator. The receiver may also be equipped with a telemetry transmitter to send information back to a remote display at the drill rig.

**Reference Line**

A predetermined line or set of surface characteristics generally along the intended path of the bore (used for reference during drilling). Mainly used when mapping bores using the DataLog System.

**Remote Display**

A device at or near the drill rig used to display the transmitter's information communicated from the receiver. This device can be used for remote steering when walkover locating is not possible.

**Roll**

The rotation about the longitudinal axis of the transmitter.

**Set the Ultrasonics**

To set the ultrasonics, click the trigger once and observe the bottom window. The number displayed for 2 seconds will now be subtracted from the total magnetic distance. The ultrasonics can be set an unlimited number of times without affecting the calibration. The ultrasonic measurement is used to accommodate the different heights of drillers.

**Slant Distance**

See Depth vs. Slant Distance vs. Range.

**Start-up = Power-up = Boot-up**

This occurs when a battery is placed in the receiver or remote display and the unit is turned on. Power on initiates a start-up sequence of display information. Calibration or locating cannot be initiated until the start-up sequence is complete.

**Start-up Sequence**

The progression of receiver start-up displays that provide information such as the firmware version in the receiver, the depth measurement mode, the voltage of the receiver's battery (if 5.07 firmware), the channel the receiver will use to send signals to the remote display at the drill; and an LCD symbol test.

**Telemetry**

The signal by which the receiver communicates to the remote display. There is a telemetry transmitter in the receiver and a telemetry receiver in the remote display.

**Transmitter**

The transmitter (also known in the industry as a sonde, beacon, or probe) fits inside the housing/drill tool and emits electromagnetic signals to aboveground surface that allow the locator to determine position, orientation, and other parameters affecting the operation. The range of the transmitter is variable and can be increased by using a Mark III Receiver.

**Trigger Clicked**

Clicking the trigger is pushing in and then releasing the trigger in less than ½ second. Generally, this action will initiate an ultrasonic measurement. For more information see "Clicking vs. Holding the Trigger" and "Ultrasonic Function" in the Receiver Section.

**Trigger In**

When the trigger is held in, the system is in "locating mode." Different types of information are available when the trigger is held in during normal locating as well as at start up. For more information see "Clicking vs. Holding the Trigger" in the Receiver Section.

**Trigger Out**

When the trigger is out or released, the system is in "tracking mode." The transmitter's pitch, roll, and distance/depth are displayed and continuously updated. The information displayed on the receiver immediately after a held-in trigger is released is dependent upon the firmware installed in the receiver. For more information see "Clicking vs. Holding the Trigger" in the Receiver Section.



**Ultrasonic Distance = Ultrasonic Measurement = Height-Above-Ground Measurement**

The receiver's height above the ground, which is displayed in the bottom window for 2 seconds after the trigger is clicked. The ultrasonic measurement is used to accommodate the different heights of drillers. For more information see "Ultrasonic Function" in the Receiver Section.

**Ultrasonic Function**

Determines the elevation the receiver is above a surface (up to a distance of 90 inches) and displays this "ultrasonic distance" in the bottom window of the receiver for 2 seconds any time the trigger is clicked (after the unit is powered up). The transmitter does not need to be active for operation of the ultrasonic function.

**Ultrasonic Transducers**

Sensors located in the two openings on the bottom of the receiver that measure the height of the receiver or the ultrasonic distance.

**V AC**

Volts alternating current.

**V DC**

Volts direct current.

## ***Appendix***

The information and tables contained in this appendix provide further assistance for confirming the position of the Transmitter. The following information is provided:

**Depth Increase in Inches per 10-foot Rod**

**Percent of Grade to Degree Conversions (1% Pitch Transmitters)**

**Percent of Grade to Degree Conversions (0.1% Pitch Transmitters or Sensitive Pitch)**

**Degree to Percent of Grade Conversions (1% Pitch Transmitters)**

**Degree to Percent of Grade Conversions (0.1% Pitch Transmitters)**

**Calculating Depth Based on Distance Between FNLP and RNLP**

**Depth Increase in Inches per 10-foot Rod**

<b>Percent</b>	<b>Depth Increase</b>		<b>Percent</b>	<b>Depth Increase</b>
<b>1</b>	1		<b>27</b>	31
<b>2</b>	2		<b>28</b>	32
<b>3</b>	4		<b>29</b>	33
<b>4</b>	5		<b>30</b>	34
<b>5</b>	6		<b>31</b>	36
<b>6</b>	7		<b>32</b>	37
<b>7</b>	8		<b>33</b>	38
<b>8</b>	10		<b>34</b>	39
<b>9</b>	11		<b>35</b>	40
<b>10</b>	12		<b>36</b>	41
<b>11</b>	13		<b>37</b>	42
<b>12</b>	14		<b>38</b>	43
<b>13</b>	15		<b>39</b>	44
<b>14</b>	17		<b>40</b>	45
<b>15</b>	18		<b>41</b>	46
<b>16</b>	19		<b>42</b>	46
<b>17</b>	20		<b>43</b>	47
<b>18</b>	21		<b>44</b>	48
<b>19</b>	22		<b>45</b>	49
<b>20</b>	24		<b>50</b>	54
<b>21</b>	25		<b>55</b>	58
<b>22</b>	26		<b>60</b>	62
<b>23</b>	27		<b>70</b>	69
<b>24</b>	28		<b>80</b>	75
<b>25</b>	29		<b>90</b>	80
<b>26</b>	30		<b>100</b>	85

**Percent of Grade to Degree Conversions  
(1% Pitch Transmitters)**

<b>Percent</b>	<b>Degree</b>	<b>Percent</b>	<b>Degree</b>	<b>Percent</b>	<b>Degree</b>	<b>Percent</b>	<b>Degree</b>
<b>1</b>	0.6	<b>26</b>	14.6	<b>51</b>	27.0	<b>76</b>	37.2
<b>2</b>	1.1	<b>27</b>	15.1	<b>52</b>	27.5	<b>77</b>	37.6
<b>3</b>	1.7	<b>28</b>	15.6	<b>53</b>	27.9	<b>78</b>	38.0
<b>4</b>	2.3	<b>29</b>	16.2	<b>54</b>	28.4	<b>79</b>	38.3
<b>5</b>	2.9	<b>30</b>	16.7	<b>55</b>	28.8	<b>80</b>	38.7
<b>6</b>	3.4	<b>31</b>	17.2	<b>56</b>	29.2	<b>81</b>	39.0
<b>7</b>	4.0	<b>32</b>	17.7	<b>57</b>	29.7	<b>82</b>	39.4
<b>8</b>	4.6	<b>33</b>	18.3	<b>58</b>	30.1	<b>83</b>	39.7
<b>9</b>	5.1	<b>34</b>	18.8	<b>59</b>	30.5	<b>84</b>	40.0
<b>10</b>	5.7	<b>35</b>	19.3	<b>60</b>	31.0	<b>85</b>	40.4
<b>11</b>	6.3	<b>36</b>	19.8	<b>61</b>	31.4	<b>86</b>	40.7
<b>12</b>	6.8	<b>37</b>	20.3	<b>62</b>	31.8	<b>87</b>	41.0
<b>13</b>	7.4	<b>38</b>	20.8	<b>63</b>	32.2	<b>88</b>	41.3
<b>14</b>	8.0	<b>39</b>	21.3	<b>64</b>	32.6	<b>89</b>	41.7
<b>15</b>	8.5	<b>40</b>	21.8	<b>65</b>	33.0	<b>90</b>	42.0
<b>16</b>	9.1	<b>41</b>	22.3	<b>66</b>	33.4	<b>91</b>	42.3
<b>17</b>	9.6	<b>42</b>	22.8	<b>67</b>	33.8	<b>92</b>	42.6
<b>18</b>	10.2	<b>43</b>	23.3	<b>68</b>	34.2	<b>93</b>	42.9
<b>19</b>	10.8	<b>44</b>	23.7	<b>69</b>	34.6	<b>94</b>	43.2
<b>20</b>	11.3	<b>45</b>	24.2	<b>70</b>	35.0	<b>95</b>	43.5
<b>21</b>	11.9	<b>46</b>	24.7	<b>71</b>	35.4	<b>96</b>	43.8
<b>22</b>	12.4	<b>47</b>	25.2	<b>72</b>	35.8	<b>97</b>	44.1
<b>23</b>	13.0	<b>48</b>	25.6	<b>73</b>	36.1	<b>98</b>	44.4
<b>24</b>	13.5	<b>49</b>	26.1	<b>74</b>	36.5	<b>99</b>	44.7
<b>25</b>	14.0	<b>50</b>	26.6	<b>75</b>	36.9	<b>100</b>	45.0

**Percent of Grade to Degree Conversions  
(0.1% Pitch Transmitters or Sensitive Pitch)**

<b>Percent</b>	<b>Degree</b>	<b>Percent</b>	<b>Degree</b>	<b>Percent</b>	<b>Degree</b>	<b>Percent</b>	<b>Degree</b>
0.1	0.1	2.6	1.5	5.1	2.9	7.6	4.3
0.2	0.1	2.7	1.5	5.2	3.0	7.7	4.4
0.3	0.2	2.8	1.6	5.3	3.0	7.8	4.5
0.4	0.2	2.9	1.7	5.4	3.1	7.9	4.5
0.5	0.3	3	1.7	5.5	3.1	8	4.6
0.6	0.3	3.1	1.8	5.6	3.2	8.1	4.6
0.7	0.4	3.2	1.8	5.7	3.3	8.2	4.7
0.8	0.5	3.3	1.9	5.8	3.3	8.3	4.7
0.9	0.5	3.4	1.9	5.9	3.4	8.4	4.8
1	0.6	3.5	2.0	6	3.4	8.5	4.9
1.1	0.6	3.6	2.1	6.1	3.5	8.6	4.9
1.2	0.7	3.7	2.1	6.2	3.5	8.7	5.0
1.3	0.7	3.8	2.2	6.3	3.6	8.8	5.0
1.4	0.8	3.9	2.2	6.4	3.7	8.9	5.1
1.5	0.9	4	2.3	6.5	3.7	9	5.1
1.6	0.9	4.1	2.3	6.6	3.8	9.1	5.2
1.7	1.0	4.2	2.4	6.7	3.8	9.2	5.3
1.8	1.0	4.3	2.5	6.8	3.9	9.3	5.3
1.9	1.1	4.4	2.5	6.9	3.9	9.4	5.4
2	1.1	4.5	2.6	7	4.0	9.5	5.4
2.1	1.2	4.6	2.6	7.1	4.1	9.6	5.5
2.2	1.3	4.7	2.7	7.2	4.1	9.7	5.5
2.3	1.3	4.8	2.7	7.3	4.2	9.8	5.6
2.4	1.4	4.9	2.8	7.4	4.2	9.9	5.7
2.5	1.4	5	2.9	7.5	4.3	10	5.7

**Degree to Percent of Grade Conversions  
(1% Pitch Transmitters)**

Degrees	Percent		Degrees	Percent
0	0.0		23	42.4
1	1.7		24	44.5
2	3.5		25	46.6
3	5.2		26	48.8
4	7.0		27	51.0
5	8.7		28	53.2
6	10.5		29	55.4
7	12.3		30	57.7
8	14.1		31	60.1
9	15.8		32	62.5
10	17.6		33	64.9
11	19.4		34	67.5
12	21.3		35	70.0
13	23.1		36	72.7
14	24.9		37	75.4
15	26.8		38	78.1
16	28.7		39	81.0
17	30.6		40	83.9
18	32.5		41	86.9
19	34.4		42	90.0
20	36.4		43	93.3
21	38.4		44	96.6
22	40.4		45	100.0

**Degree to Percent of Grade Conversions  
(0.1% Pitch Transmitters)**

Degrees	Percent		Degrees	Percent
0.1	0.2		3.1	5.4
0.2	0.3		3.2	5.6
0.3	0.5		3.3	5.8
0.4	0.7		3.4	5.9
0.5	0.9		3.5	6.1
0.6	1.0		3.6	6.3
0.7	1.2		3.7	6.5
0.8	1.4		3.8	6.6
0.9	1.6		3.9	6.8
1	1.7		4	7.0
1.1	1.9		4.1	7.2
1.2	2.1		4.2	7.3
1.3	2.3		4.3	7.5
1.4	2.4		4.4	7.7
1.5	2.6		4.5	7.9
1.6	2.8		4.6	8.0
1.7	3.0		4.7	8.2
1.8	3.1		4.8	8.4
1.9	3.3		4.9	8.6
2	3.5		5	8.7
2.1	3.7		5.1	8.9
2.2	3.8		5.2	9.1
2.3	4.0		5.3	9.3
2.4	4.2		5.4	9.5
2.5	4.4		5.5	9.6
2.6	4.5		5.6	9.8
2.7	4.7		5.7	10.0
2.8	4.9			
2.9	5.1			
3	5.2			

## Calculating Depth Based on Distance Between FNLP and RNLP

It is possible to estimate the transmitter's depth should the information displayed in the depth/distance window become unreliable. This is only possible if the pitch and negative locate points are reliable and the ground surface is level.

To estimate the transmitter's depth, first measure the distance between the FNLP and the RNLP. The pitch of the transmitter must also be reliably known. Using the Depth Estimation Table below, find the divider that most closely corresponds to the transmitter's pitch. Then use the following formula to estimate the depth:

$$\text{Depth} = \frac{\text{Distance between FNLP and RNLP}}{\text{Divider}}$$

For example, if the transmitter's pitch is 34% then the corresponding divider value (from the table) is 1.50. In this example, the distance between the FNLP and the RNLP is 11.5 ft (3.5 m). The depth would be:

$$\text{Depth} = \frac{11.5 \text{ ft}}{1.50} = 7.66 \text{ ft or approximately } 7.7 \text{ ft (2.35 m)}$$

**Depth Estimation Table**

Pitch	Divider	Pitch	Divider	Pitch	Divider	Pitch	Divider
0	1.41	26	1.47	52	1.62	78	1.84
2	1.41	28	1.48	54	1.63	80	1.85
4	1.42	30	1.48	56	1.64	82	1.87
6	1.42	32	1.49	58	1.66	84	1.89
8	1.42	34	1.50	60	1.68	86	1.91
10	1.42	36	1.51	62	1.69	88	1.93
12	1.43	38	1.52	64	1.71	90	1.96
14	1.43	40	1.54	66	1.73	92	1.98
16	1.43	42	1.55	68	1.74	94	2.00
18	1.44	44	1.56	70	1.76	96	2.02
20	1.45	46	1.57	72	1.78	98	2.04
22	1.45	48	1.59	74	1.80	100	2.06
24	1.46	50	1.60	76	1.82		



**Notes**

## **REMOTE TELEMETRY LICENSE**

The attached license is required by the United States Federal Communications Commission (“FCC”) for operation of the DigiTrak<sup>®</sup> Remote Receiver. DigiTrak<sup>®</sup> Remote Receivers are identified by the orange arrow and the FCC ID #KKG007 on the label below the battery compartment door.

This license was approved by the FCC under an overall license issued to Digital Control Incorporated. An operator of a DigiTrak<sup>®</sup> Remote Receiver in the United States is no longer required to apply for a separate personal license as previously required.

This license authorizes operation of the DigiTrak<sup>®</sup> Remote Receiver in the United States only. The DigiTrak<sup>®</sup> Remote Receiver shall only be operated in accordance with the rules and regulations of the FCC and as outlined in the owner’s manual accompanying this equipment. No modifications may be made to the DigiTrak<sup>®</sup> Remote Receiver or other DigiTrak<sup>®</sup> equipment.

It is the operator’s responsibility to obtain proper licensing for operation of the DigiTrak<sup>®</sup> Remote Receiver outside of the United States.



Federal Communications Commission  
Wireless Telecommunications Bureau

Page 1 of 1  
76

RADIO STATION AUTHORIZATION

Licensee: DIGITAL CONTROL

FCC Registration  
Number (FRN): 0013772017

GENERAL COUNSEL  
DIGITAL CONTROL  
19625 62ND AVE SOUTH SUITE B103  
KENT WA 98032

Call Sign WPIJ819	File Number 0002245398
Radio Service IG - Industrial/Business Pool, Conventional	
Regulatory Status PMRS	
Frequency Coordination Number	

Grant Date 07-20-2005	Effective Date 07-20-2005	Expiration Date 09-14-2015	Print Date 07-20-2005
--------------------------	------------------------------	-------------------------------	--------------------------

STATION TECHNICAL SPECIFICATIONS

Fixed Location Address or Mobile Area of Operation

Loc. 1 Area of Operation  
Operating Nationwide including Hawaii, Alaska, and US Territories.

Antennas

Loc. No.	Ant. No.	Frequencies (MHZ)	Sta. CIs.	No. Units	No. Pagers	Emission Designator	Output Power (watts)	ERP (watts)	Ant. Ht./Tp meters	Ant. AAT meters	Construct Deadline Date
1	1	464.50000	M01	20000	0	25K9F1D	0.080	0.080			
1	1	464.55000	M01	20000	0	25K9F1D	0.080	0.080			
1	1	469.50000	M01	20000	0	25K9F1D	0.080	0.080			
1	1	469.55000	M01	20000	0	25K9F1D	0.080	0.080			

Control Points

Control Address  
Pt. No.

1 425 SW 41ST ST  
City RENTON County State WA Telephone Number (425)251-0701

Conditions:

Pursuant to Section 309(h) of the Communications Act of 1934, as amended, 47 U.S.C. Section 309(h), this license is subject to the following conditions: This license shall not vest in the licensee any right to operate the station nor any right in the use of the frequencies designated in the license beyond the term thereof nor in any other manner than authorized herein. Neither the license nor the right granted thereunder shall be assigned or otherwise transferred in violation of the Communications Act of 1934, as amended. See 47 U.S.C. Section 310(d). This license is subject in terms to the right of use or control conferred by Section 706 of the Communications Act of 1934, as amended. See 47 U.S.C. Section 606.

FCC 601 - LM  
December 2004

## **LIMITED WARRANTY**

Digital Control Incorporated ("DCI") warrants that when shipped from DCI each DCI product ("DCI Product") will conform to DCI's current published specifications in existence at the time of shipment and will be free, for the warranty period ("Warranty Period") described below, from defects in materials and workmanship. The limited warranty described herein ("Limited Warranty") is not transferable, shall extend only to the first end-user ("User") purchasing the DCI Product from either DCI or a dealer expressly authorized by DCI to sell DCI Products ("Authorized DCI Dealer"), and is subject to the following terms, conditions and limitations:

1. A Warranty Period of twelve (12) months shall apply to the following new DCI Products: receivers/locators, remote displays, battery chargers and rechargeable batteries, and DataLog<sup>®</sup> modules and interfaces. A Warranty Period of ninety (90) days shall apply to all other new DCI Products, including transmitters, accessories, and software programs and modules. Unless otherwise stated by DCI, a Warranty Period of ninety (90) days shall apply to: (a) a used DCI Product sold either by DCI or by an Authorized DCI Dealer who has been expressly authorized by DCI to sell such used DCI Product; and (b) services provided by DCI, including testing, servicing, and repairing an out-of-warranty DCI Product. The Warranty Period shall begin from the later of: (i) the date of shipment of the DCI Product from DCI, or (ii) the date of shipment (or other delivery) of the DCI Product from an Authorized DCI Dealer to User.

2. DCI's sole obligation under this Limited Warranty shall be limited to either repairing, replacing, or adjusting, at DCI's option, a covered DCI Product that has been determined by DCI, after reasonable inspection, to be defective during the foregoing Warranty Period. All warranty inspections, repairs and adjustments must be performed either by DCI or by a warranty claim service authorized in writing by DCI. All warranty claims must include proof of purchase, including proof of purchase date, identifying the DCI Product by serial number.

**3. The Limited Warranty shall only be effective if: (i) within fourteen (14) days of receipt of the DCI Product, User mails a fully-completed Warranty Registration Card to DCI; (ii) User makes a reasonable inspection upon first receipt of the DCI Product and immediately notifies DCI of any apparent defect; and (iii) User complies with all of the Warranty Claim Procedures described below.**

## **WHAT IS NOT COVERED**

This Limited Warranty excludes all damage, including damage to any DCI Product, due to: failure to follow DCI's user's manual and other DCI instructions; abuse; misuse; neglect; accident; fire; flood; Acts of God; improper applications; connection to incorrect line voltages and improper power sources; use of incorrect fuses; overheating; contact with high voltages or injurious substances; or other events beyond the control of DCI. This Limited Warranty does not apply to any equipment not manufactured or supplied by DCI nor, if applicable, to any damage or loss resulting from use of any DCI Product outside the designated country of use. By accepting a DCI Product, User agrees to carefully evaluate the suitability of the DCI Product for User's intended use and to thoroughly read and strictly follow all instructions supplied by DCI (including any updated DCI Product information which may be obtained at the above DCI website). In no event shall this Limited Warranty cover any damage arising during shipment of the DCI Product to or from DCI.

User agrees that the following will render the above Limited Warranty void: (i) alteration, removal or tampering with any serial number, identification, instructional, or sealing labels on the DCI Product, or (ii) any unauthorized disassembly, repair or modification of the DCI Product. In no event shall DCI be responsible for the cost of or any damage resulting from any changes, modifications, or repairs to the DCI Product not expressly authorized in writing by DCI, and DCI shall not be responsible for the loss of or damage to the DCI Product or any other equipment while in the possession of any service agency not authorized by DCI.

DCI reserves the right to make changes in design and improvements upon DCI Products from time to time, and User understands that DCI shall have no obligation to upgrade any previously manufactured DCI Product to include any such changes.

The foregoing Limited Warranty is DCI's sole warranty and is made in place of all other warranties, express or implied, including but not limited to the implied warranties of merchantability and fitness for a particular purpose, implied warranty of non-infringement, and any implied warranty arising from course of performance, course of dealing, or usage of trade. If DCI has substantially complied with the warranty claim procedures described below, such procedures shall constitute User's sole and exclusive remedy for breach of the Limited Warranty.

**In no event shall DCI be liable for any indirect, special, incidental, or consequential damages or for any cover, loss of information, profit, revenue or use based upon any claim by User for breach of warranty, breach of contract, negligence, strict liability, or any other legal theory. In no event shall DCI's liability exceed the amount User has paid for the DCI Product. To the extent that any applicable law does not allow the exclusion or limitation of incidental, consequential or similar damages, the foregoing limitations regarding such damages shall not apply.**

This Limited Warranty gives you specific legal rights, and you may also have other rights which vary from state to state. This Limited Warranty shall be governed by the laws of the State of Washington.

## **WARRANTY CLAIM PROCEDURES**

1. If you are having problems with your DCI Product, you must first contact the Authorized DCI Dealer where it was purchased. If you are unable to resolve the problem through your Authorized DCI Dealer, contact DCI's Customer Service Department in Kent, Washington, USA at the above telephone number between 6:00 a.m. and 6:00 p.m. Pacific Time and ask to speak with a customer service representative. (The above "800" number is available for use only in the USA and Canada.) Prior to returning any DCI Product to DCI for service, you must obtain a Return Merchandise Authorization (RMA) number. Failure to obtain a RMA may result in delays or return to you of the DCI Product without repair.

2. After contacting a DCI customer service representative by telephone, the representative will attempt to assist you in troubleshooting while you are using the DCI Product during actual field operations. Please have all related equipment available together with a list of all DCI Product serial numbers. It is important that field troubleshooting be conducted because many problems do not result from a defective DCI Product, but instead are due to either operational errors or adverse conditions occurring in the User's drilling environment.

3. If a DCI Product problem is confirmed as a result of field troubleshooting discussions with a DCI customer service representative, the representative will issue a RMA number authorizing the return of the DCI Product and will provide shipping directions. You will be responsible for all shipping costs, including any insurance. If, after receiving the DCI Product and performing diagnostic testing, DCI determines the problem is covered by the Limited Warranty, required repairs and/or adjustments will be made, and a properly functioning DCI Product will be promptly shipped to you. If the problem is not covered by the Limited Warranty, you will be informed of the reason and be provided an estimate of repair costs. If you authorize DCI to service or repair the DCI Product, the work will be promptly performed and the DCI Product will be shipped to you. You will be billed for any costs for testing, repairs and adjustments not covered by the Limited Warranty and for shipping costs. In most cases, repairs are accomplished within 1 to 2 weeks.

4. DCI has a limited supply of loaner equipment available. If loaner equipment is required by you and is available, DCI will attempt to ship loaner equipment to you by overnight delivery for your use while your equipment is being serviced by DCI. DCI will make reasonable efforts to minimize your downtime on warranty claims, limited by circumstances not within DCI's control. If DCI provides you loaner equipment, your equipment must be received by DCI no later than the second business day after your receipt of loaner equipment. You must return the loaner equipment by overnight delivery for receipt by DCI no later than the second business day after your receipt of the repaired DCI Product. Any failure to meet these deadlines will result in a rental charge for use of the loaner equipment for each extra day the return of the loaner equipment to DCI is delayed.